

1976

# Concentration and determination of trace organic pollutants in water

Richard Chi-Yuen Chang  
*Iowa State University*

Follow this and additional works at: <https://lib.dr.iastate.edu/rtd>

 Part of the [Analytical Chemistry Commons](#), and the [Oil, Gas, and Energy Commons](#)

## Recommended Citation

Chang, Richard Chi-Yuen, "Concentration and determination of trace organic pollutants in water " (1976). *Retrospective Theses and Dissertations*. 6264.  
<https://lib.dr.iastate.edu/rtd/6264>

This Dissertation is brought to you for free and open access by the Iowa State University Capstones, Theses and Dissertations at Iowa State University Digital Repository. It has been accepted for inclusion in Retrospective Theses and Dissertations by an authorized administrator of Iowa State University Digital Repository. For more information, please contact [digirep@iastate.edu](mailto:digirep@iastate.edu).

## INFORMATION TO USERS

This material was produced from a microfilm copy of the original document. While the most advanced technological means to photograph and reproduce this document have been used, the quality is heavily dependent upon the quality of the original submitted.

The following explanation of techniques is provided to help you understand markings or patterns which may appear on this reproduction.

1. The sign or "target" for pages apparently lacking from the document photographed is "Missing Page(s)". If it was possible to obtain the missing page(s) or section, they are spliced into the film along with adjacent pages. This may have necessitated cutting thru an image and duplicating adjacent pages to insure you complete continuity.
2. When an image on the film is obliterated with a large round black mark, it is an indication that the photographer suspected that the copy may have moved during exposure and thus cause a blurred image. You will find a good image of the page in the adjacent frame.
3. When a map, drawing or chart, etc., was part of the material being photographed the photographer followed a definite method in "sectioning" the material. It is customary to begin photoing at the upper left hand corner of a large sheet and to continue photoing from left to right in equal sections with a small overlap. If necessary, sectioning is continued again -- beginning below the first row and continuing on until complete.
4. The majority of users indicate that the textual content is of greatest value, however, a somewhat higher quality reproduction could be made from "photographs" if essential to the understanding of the dissertation. Silver prints of "photographs" may be ordered at additional charge by writing the Order Department, giving the catalog number, title, author and specific pages you wish reproduced.
5. PLEASE NOTE: Some pages may have indistinct print. Filmed as received.

**Xerox University Microfilms**

300 North Zeeb Road  
Ann Arbor, Michigan 48106

77-1019

CHANG, Richard Chi-Yuen, 1946-  
CONCENTRATION AND DETERMINATION OF TRACE  
ORGANIC POLLUTANTS IN WATER.

Iowa State University, Ph.D., 1976  
Chemistry, analytical

**Xerox University Microfilms**, Ann Arbor, Michigan 48106

Concentration and determination of trace organic  
pollutants in water

by

Richard Chi-Yuen Chang

A Dissertation Submitted to the  
Graduate Faculty in Partial Fulfillment of  
The Requirements for the Degree of  
DOCTOR OF PHILOSOPHY

Department: Chemistry

Major: Analytical Chemistry

Approved:

Signature was redacted for privacy.

In Charge of Major Work

Signature was redacted for privacy.

For the Major Department

Signature was redacted for privacy.

For the Graduate College

Iowa State University  
Ames, Iowa

1976

## TABLE OF CONTENTS

	Page
INTRODUCTION	1
CONCENTRATION AND DETERMINATION OF PHENOLS	3
Review of Related Work	3
Experimental	7
Apparatus and reagents	7
Gas chromatographs	7
Reagents	7
Techniques and procedure	8
Resin cleaning	8
Sorption column preparation	9
Analytical procedure for determination of phenols	9
Results and Discussion	13
Development of analytical method	13
The pH of water sample	13
The size and geometry of sorption column	14
Hardness of water sample	14
Oxidation of phenols	15
Chlorination of phenols	15
Elution of phenols	16
Gas chromatographic separation of phenols	17
Recovery studies	18
Analysis of wastewater for phenols	24
Interference studies	24
CONCENTRATION AND DETERMINATION OF TRACE ORGANICS	28
Review of Related Work	28
Experimental	32
Apparatus and reagents	32
Gas chromatograph	32
Mini-sampler	33
Reagents	33
Resins	33
Techniques and procedures	36
Sorption columns preparation and conditioning	36
Packing and conditioning of gas chromatographic columns	37
Analytical procedure-recovery efficiency studies	37
Analytical procedure-real water samples	39

Results and Discussion	39
Development of analytical method	39
Direct aqueous-injection gas chromatography	39
Determination of trace organics	39
Determination of traces of water	43
Single sorption column	45
Double sorption columns	47
Recovery studies	49
Method parameters	54
Desorption temperature	54
Desorption time	58
Sample size	58
Linearity	60
Sensitivity	60
Analysis of real water for organics	60
Conclusion	64
CONCENTRATION AND DETERMINATION OF HALOMETHANES	65
Review of Related Work	65
Experimental	66
Apparatus and reagents	66
Gas chromatograph	66
Extraction apparatus	67
Water	67
Resin	67
Techniques and procedure	67
Sorption columns preparation	67
Packing and conditioning of Tenax-GC column	67
Analytical procedure for determination of halomethanes	69
Results and Discussion	70
Recovery studies	70
Analysis of water for halomethanes	71
Method parameters	74
Elution of halomethanes	74
Gas chromatographic column	76
Sensitivity	76
Storage of sorbed halomethanes	76
Conclusion	77
SUGGESTIONS FOR FUTURE WORK	78
LITERATURE CITED	80
ACKNOWLEDGEMENTS	86

## INTRODUCTION

Although the inorganic constituents and biological organisms in the potable water supplies of cities and towns are well characterized, little is known about the soluble organic constituents naturally present or resulting from some contamination. Furthermore, analytical methods for determining the types and concentrations of organic pollutants in waste effluents from various industries are badly needed to monitor their effluents discharge into the rivers and streams and to check their wastewater treatment processes.

There is considerable interest in establishing what organic pollutants are actually present in various drinking water supplies and a pressing need for more information regarding the identity and amounts of organic contaminants in waste effluents. Therefore adequate, simple and reliable methods of analyzing water for trace organic pollutants must be developed (1,2).

The purpose of this work was to improve the existing analytical methods and develop new analytical methods to meet special need for concentrating and determining of trace organic contaminants in water.

The organization of this thesis has therefore dictated a three-part division. The new selective method for phenols will be treated first in its entirety, followed by the improved method for trace organic pollutants using resin extraction-

thermal desorption method. Finally, a rapid method for halo-methanes will be briefly described. The development of the analytical methods, method parameters and analysis of real water samples will be presented in each part.



## CONCENTRATION AND DETERMINATION OF PHENOLS

Phenols are widely distributed by man and, at trace levels, by nature. Phenols are present in the waste effluent waters from organic chemical, petroleum, plastic and steel industries. They are considered pollutants because they increase oxygen demand and cause an unpleasant taste in potable water. Phenols also have toxicological effects on man and animals. The discharge of phenolic wastes into natural waters creates a harmful environment to fish and other aquatic life forms (3,4). Phenols contribute an unpleasant medicinal odor and taste to drinking water at concentrations of order of 0.01 to 0.1 ppm (5). The U.S. Public Health Services Drinking Water Standards suggests that phenolic compounds shall not exceed an upper limit of 0.001 ppm in acceptable water supplied (6). There is a pressing need for a rapid, reliable procedure applicable to a wide range of concentrations, with particular emphasis on the determination of phenols at ppb level.

## Review of Related Work

The literature on the subject is very extensive and a comprehensive review of all references would be inappropriate for this study. Consequently, only selective papers describing techniques currently in use will be discussed.

Total phenols have been determined routinely for about thirty years by the condensation reaction with 4-aminoantipyrine (4-AAP). This reaction was first reported by Emerson

(7,8) and Emerson and Kelly (9) and is the basis for the "Standard Methods" used at present by the American Society for Testing and Materials (ASTM) (10) and the American Public Health Association (11). Other colorimetric reagents which have been used included quinonechloroimide (12, 13), diazotized sulfanilic acid (14), diazotized p-nitroaniline (15), p-dimethylaminobenzaldehyde (16), nitrous acid (17) and 3-methyl-2-benzenethioazolinone hydrazone (18). Although the colorimetric methods are sensitive, they cannot differentiate between substituted phenols. Since it is important to identify individual phenols in contaminated water in order to determine the source of contamination and toxicological effects of each phenolic compound, this constitutes an important limitation of the colorimetric reagents. Furthermore, common inorganic substances present in water can give positive tests when phenols are absent. While this problem is overcome by isolating the phenols by a steam distillation step, this introduces a greater potential for error and transforms a basically simple method into a rather complicated one.

Other techniques which have been used for total phenolic analysis included ultraviolet absorption spectrometry (19,20, 21,22), infrared-absorption spectroscopy (23,24) and electrochemical techniques (25,26). However these methods do not exhibit the high sensitivity required for the analysis of traces of phenolic compounds.

Paper, thin-layer and ion-exchange chromatography have been used successfully to separate complex mixtures of phenolic compounds but these methods are feasible for qualitative work only (27-34).

Gas-liquid chromatography has been used to determine phenols in wastewaters (35,36,37). The American Society for Testing and Materials (38) and the American Public Health Association (39) recommend a direct aqueous-injection procedure for the gas chromatographic determination of phenols, cresols, and mono- and dichloro-phenols in water. The method specifies a single stainless steel column, 10 ft by 1/8 in. o.d., packed with 20% Carbowax 20M. A flame ionization detector is recommended. This method is not applicable for samples which contain less than 1 ppm of phenolic compounds unless either a larger sample or preliminary concentration step is used.

Some of these problems are alleviated by a procedure which involved absorption of phenols on carbon, extraction of the carbon with chloroform to remove the phenols, concentration of the phenols in the chloroform by evaporation, and determination of phenols in the chloroform extract by gas chromatography (40). The most significant limitations of this method are that it is difficult to avoid losses of phenols caused by incomplete absorption on the carbon, incomplete extraction with the chloroform, or evaporative losses during the

concentration of the chloroform. Another limitation is that this procedure is not specific for phenols, and other organics present in water can interfere with the gas chromatographic determination of phenols unless elaborate cleanup procedures are performed on the chloroform extract (41).

The absorption of phenols from acidic solution on porous polymer resins such as Amberlite XAD-2 has been shown to form the basis for a simple and accurate method for determining organics, including phenols, in water (42,43). XAD-2 resin effectively sorbs phenols and other organic compounds from water, although low recoveries are obtained for phenol itself.

A method was sought that would concentrate all phenols effectively and would permit separation of phenols from other organics that might be present in water.

Fritz and Tateda (44) reported that the sorption of phenols on anion-exchange resin is greater in alkaline than acidic solution, in which the dissociation is depressed. Preliminary experiments showed that phenols are effectively retained from water when samples of water containing low concentrations of phenols are made basic and passed through a column containing A-26 anion-exchange resin. Experiments by M. D. Arguello and M. D. Grieser in our laboratory indicates that low concentrations of neutral organic compounds such as naphthalene were only 0 to 3% retained by the anion-exchange column. Thus a reasonable selectivity for phenols over other organics was indicated.

The basis of the analytical method reported in this study is as follows: Phenols are taken up as phenolate ions by passing a basic water sample through a column of A-26 anion-exchange resin in the hydroxyl form. Any neutral organics retained by the resin are removed by washing with basic methanol. Phenolate ions continue to be held by the resin during this washing step and are then converted to the molecular form by washing the column with aqueous hydrochloric acid. The phenols are subsequently eluted from the column with acetone-water. The hydrochloric acid and acetone-water effluents are each extracted with methylene chloride. The organic phases are concentrated by evaporation, and the phenols are separated by gas chromatography.

## Experimental

### Apparatus and reagents

Gas chromatographs A Hewlett-Packard Model 5711A gas chromatograph equipped with a linear temperature programmer and dual flame ionization detectors was used for the majority of this work. A Hewlett-Packard Model 5756B equipped with a linear temperature programmer and dual flame ionization detectors was also used in this work. All chromatograms were recorded on a Fisher Recordall Series 5000 or a Hewlett-Packard Model 7128A strip chart recorder.

Reagents The phenols used to prepare the standard water samples were purchased from Chem Services Inc., 851

Lincoln Avenue, West Chester, Pennsylvania and were used as received.

### Techniques and procedure

Distilled water was freed of detectable organics by passing it through a column containing clean XAD-2 and activated charcoal.

Acetone was distilled to remove any high boiling impurities.

All other chemicals were of reagent quality.

Resin cleaning The A-26 macroreticular anion-exchange resin was obtained from Rohm and Haas, 500 Richmond Street, Philadelphia, Pennsylvania. The resin was first screened to remove any resin beads smaller than 60 mesh, which restricted flow through sorption columns, and then subjected to a thorough cleaning procedure to remove organic impurities left by the manufacturing process.

The procedure consisted of placing the resin in a sintered glass filter attached to a suction flask with the vacuum adjusted so that solvents flowed slowly through the resin. The resin was purified by sequential wash with 2 M sodium hydroxide, purified distilled water, 4 M hydrochloric acid, purified distilled water and acetone. This sequence of washing was repeated until no color was apparent in the final acetone wash (generally one to three times). The resin was finally extracted with acetone for 24 hours in a Soxhlet extractor.

Sorption column preparation      The apparatus used for extracting phenols from water is shown in Figure 1. With the upper 1-liter reservoir detached, a clean silanized glass wool was inserted near the stopcock of the glass column, 6 in. by 0.5 in. o.d., to retain the resin. The A-26 resin was added as a water slurry until the resin bed was within about one half inch of the top of the column. The column was placed in the hydroxy form by passing approximately 20 ml of 0.1 M sodium hydroxide through the resin. Excess sodium hydroxide was washed from the resin bed with 50 ml of purified distilled water.

Analytical procedure for determination of phenols

Phenols in water were determined according to the following procedure:

1. If phenols standards were added to water containing chlorine, 15 to 25 mg of hydroxylamine was added and allowed to stir for at least 5 minutes before proceeding. 15 to 25 mg of sodium hydrosulfite was added to the water sample, and the pH was adjusted to between 12.0 and 12.5 with 2 M sodium hydroxide. A 500-ml sample of water was usually used.

2. If a precipitate formed, the sample was allowed to sit for about 15 minutes to coagulate. Then the supernatant liquid was decanted through a medium porosity, 150-ml sintered glass filter attached to a suction flask. The precipitate was washed into the filter with a minimum amount of water, then washed with approximately 50 ml of distilled water.

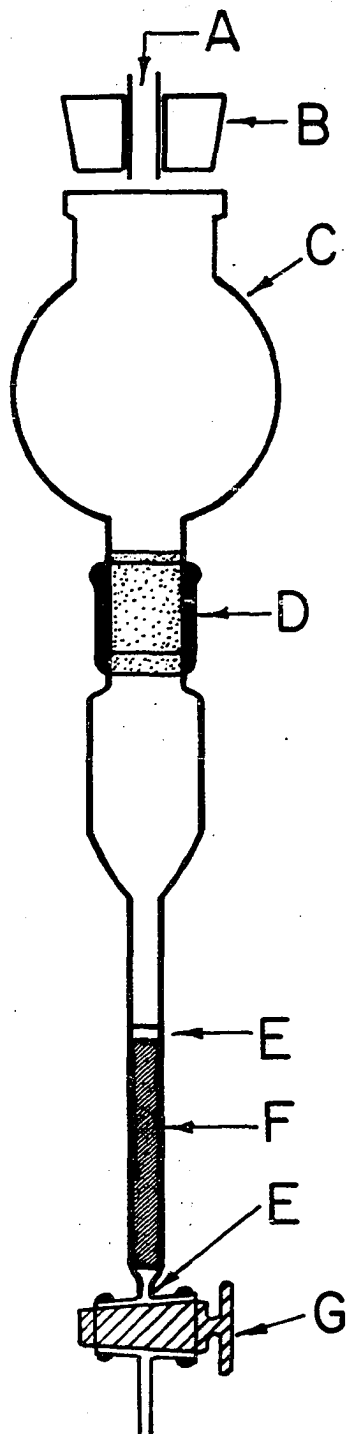

Figure 1. Apparatus for extracting phenols from water: (A) pure inert gas pressure source; (B) caps; (C) 1-liter reservoir; (D) 24/40 taper; (E) silanized glass wool plugs; (F) 1/2 in. by 6 in. glass column packed with A-26 anion-exchange resin; (G) Teflon plug stopcock



3. The filtered water was poured into the reservoir of the absorption column and allowed to flow through the resin column at a rate of 10 to 15 ml/min. When the liquid level reached the top of the resin bed, the column was washed with 25 ml of alkaline methanol (2 ml of 2 M sodium hydroxide in 23 ml of methanol) and 25 ml of distilled water.

4. The column was eluted first with 25 ml of 4 M hydrochloric acid, then with 25 ml of distilled water into a 125 ml separatory funnel. The eluate was extracted with 25 ml of methylene chloride in a separatory funnel. The phases were allowed to separate. The lower methylene chloride layer was drained into a second 125 ml separatory funnel and the aqueous layer was discarded.

5. The column was eluted again with 30 ml of 5 to 1 acetone-water followed by 50 ml of distilled water into the separatory funnel containing methylene chloride. The separatory funnel was shaken to extract the phenols into methylene chloride layer and the aqueous layer was discarded.

6. Solutions of phenols in acetone-methylene chloride were concentrated by evaporation in a specially designed flask with an attached Snyder column which is shown in Figure 2. The organic solvent was evaporated over a steam bath until the volume was reduced to approximately 0.5 ml. The evaporating flask was removed from the steam and sprayed immediately with acetone to condense the vapors inside. The volume of the solvent was adjusted to exactly 1.0 ml with acetone.

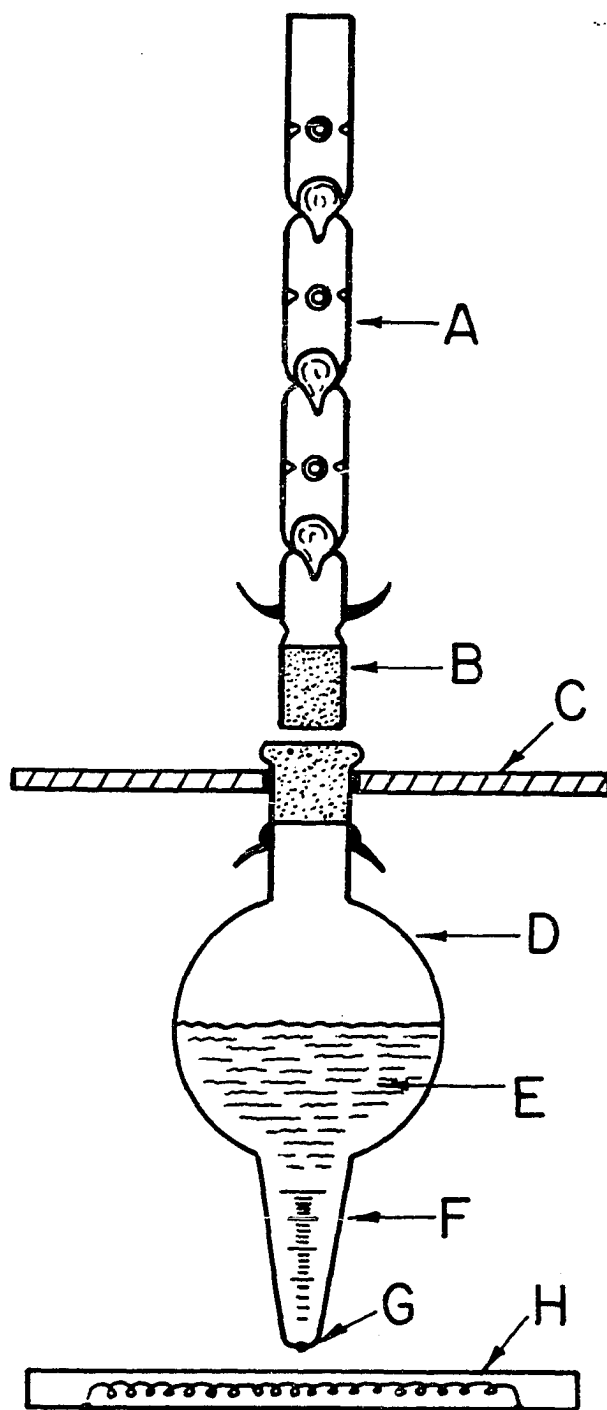

Figure 2. Concentration apparatus: (A) Snyder distillation column; (B) 14/20 taper; (C) bakelite heat shield covered with Al foil; (D) approximately 50 ml vessel; (E) organic layer; (F) graduated and calibrated taper; (G) small boiling chip; (H) steam bath

7. An aliquot of the acetone solution (2 microliters) was injected into the gas chromatograph for analysis. Phenols were identified by comparing their retention times with standards. Their concentrations were determined by comparing either their peak heights or areas with a previously prepared calibration curve.

## Results and Discussion

### Development of analytical method

In developing the analytical method the effect of various experimental parameters was studied by adding 1.0 ml of acetone solution containing known concentrations of various phenols to 500 ml water samples. The recovery of phenols was determined by comparing the peak heights of phenols in the standard acetone solution. These include the following: the pH of water sample, the size and geometry of the sorption column, hardness of water sample, oxidation of phenols, chlorination of phenols, elution of phenols and gas chromatographic separation of phenols.

The pH of water sample As expected, the recovery of phenols was found to be a function of the pH of the sample. In general phenols are completely retained on the resin if the pH of the sample is at least two units higher than the  $pK_a$  of the phenol, and all phenols are retained at pH between 12.0 and 12.5. Quantitative recovery of phenols can be attained from sample volumes up to 1000 ml, but not from larger sample

volumes.

The size and geometry of sorption column      The size and geometry of the adsorption column have little effect on the recovery of phenols provided sufficient capacity is provided. Bicarbonate in water can effectively compete with phenols for anion exchange sites on the resin so a large excess of capacity is required when phenols are determined in hard water samples. A column approximately 1/2 in. x 6 in. assures a sufficient excess of capacity, although somewhat smaller columns have been found generally to be quite effective.

Hardness of water sample      Some very hard water samples contained sufficient bicarbonate to form a copious precipitate of calcium or magnesium carbonate when the sample was made basic with sodium hydroxide. Attempts to avoid precipitation by first adding a complexing agent such as EDTA or tartrate were not effective. EDTA prevented precipitation but phenol recoveries dropped precipitously. Tartrate prevented precipitation in solution but a precipitate formed at the top of the column and stopped the flow completely. The carbonate precipitate can be effectively removed by filtration. This was best done by allowing the precipitate to coagulate for 15 to 20 min, then filtering it through a sintered glass filter. It was found that paper filters required tedious and lengthy cleaning procedures to avoid introduction of impurities from the paper.

Oxidation of phenols It was found that appreciable fractions of phenols were lost through oxidation in basic solutions and during filtration and column sorption if preventative measures were not taken. Standing at pH 12.5 resulted in complete loss of phenol within 4 hours and p-cresol within 24 hours. Loss of phenols during slow filtrations through filters clogged with calcium carbonate was variable but generally was appreciable, ranging up to 40% of the amount added. No phenols were found absorbed on the precipitate and thus the losses were attributed to oxidation. When sodium hydrosulfite was added phenol losses were negligible in basic solutions and were reduced during slow filtrations. Allowing the precipitates to coagulate prior to filtration and decanting the clear water quickly through the filter reduced losses during filtration to undetectable levels.

Chlorination of phenols Chlorine in drinking water has been reported to cause chlorination of phenols (45). During the present study it was observed that low recoveries of phenol and alkyl phenols added to tap water coincided with enhanced recoveries of chlorinated phenols. Addition of low concentrations of chloramine T to very dilute aqueous solutions of phenols caused similar results. Letting 3,5-dimethylphenol solutions in chlorinated tap water stand for a few minutes resulted in 40% loss. The new GC peaks were positively identified by mass spectrometry as being the di- and tri-

chloro-dimethylphenols. Chlorination reactions during the determination of phenols can be prevented simply by removing the chlorine by addition of hydroxylamine hydrochloride a few minutes before the solution is made basic. On real samples however, it must be recognized that chlorination reactions may have occurred before the sample was taken.

Elution of phenols Elution of phenols from the anion exchange column was accomplished by first converting them to the molecular form with hydrochloric acid. However, phenols in the molecular form were still partially retained on the column by sorption so an organic solvent must also be used for elution. Elution with methanol mixed with aqueous hydrochloric acid was fairly effective, but aqueous hydrochloric acid mixed with either acetone or acetonitrile was found to be more effective and easier to handle. However, evaporative concentration of acetone or acetonitrile solutions containing hydrochloric acid often produced dark colored solutions and subsequent gas chromatographic analysis showed low results for phenols. Possible condensation reactions in the organic solvent are catalyzed by hydrochloric acid.

These difficulties were avoided by elution of the resin with aqueous hydrochloric acid and then with water, followed by extraction of any phenols with methylene chloride. The remaining phenols were eluted from the resin with acetone (or better with 5:1 acetone-water), followed by extraction of the eluted phenols into methylene chloride. This procedure

effectively eluted phenols from the column and removed the bulk of the water from the acetone-methylene chloride solution of the phenols. Trace amounts of water remaining in this solution were removed by virtue of a ternary, low boiling azeotrope formed between methylene chloride, acetone, and water and thus no drying step was required.

Gas chromatographic separation of phenols In this work emphasis was placed on developing an effective method for isolating and concentrating phenols quantitatively from water. Conditions for gas chromatographic separation of typical phenolic mixture were achieved, but no attempt was made to develop a universal separation condition for phenolic mixtures. The following two sets of chromatographic conditions were found to be satisfactory:

1. Liquid Phase: 5% OV-17

Solid Phase: Chromosorb W AW DMCS

Column Dimension: 6 ft by 0.125 in. o.d. stainless  
steel

Detector: FID

Temperature:

Detector: 275 C

Column: Initial 115 C, followed by 16 C/min  
increase to 230 C and final hold of  
four minutes

2. Packing: Tenax-GC, 60-80 mesh

Column Dimension: 18 in. by 0.25 in. o.d. stainless  
steel

Detector: FID

Helium Flow: 40 ml/min

Temperature;

Detector: 300 C

Injection: 250 C

Column: Initial 190 C for one minute then 10  
C/min increase to 270 C and final  
hold of four minutes.

Typical chromatograms are shown in Figures 3 and 4. phenols studied are resolved satisfactorily on an OV-17 column although less tailing of solvent peaks can be achieved on a short Tenax-GC column.

#### Recovery studies

Known amounts of several phenols were added to Iowa State University tap water (approximately 450 ppm hardness) and analyses were performed by the procedure described above. Results are summarized in Table 1. A sample containing the first eight phenols was analyzed nine times with the average results as given in the first recovery column. Here the average phenol recovery was 97.7% with a standard deviation of 9.7%. The result for 2-naphthol is an average of three separate determinations in a sample containing 2-naphthol plus



Figure 3. Separation of a standard mixture of phenols on OV-17 column. Peak order: (A) solvent impurity; (B) phenol; (C) o-cresol; (D) p-cresol; (E) 3,5-dimethylphenol; (F) p-chlorophenol; (G) 4-chloro-3-methylphenol; (H) 2,4,6-trichlorophenol and (I) pentachlorophenol. Separation obtained on a 1/8 in. x 6 ft S.S. column packed with 5% OV-17 on Chromosorb W-AW-DMCS, 60/80 mesh. Helium flow rate was 27 ml/min. Temperature was programmed from 115 C to 230 C at 16°/min and held at 230 C for 4 min

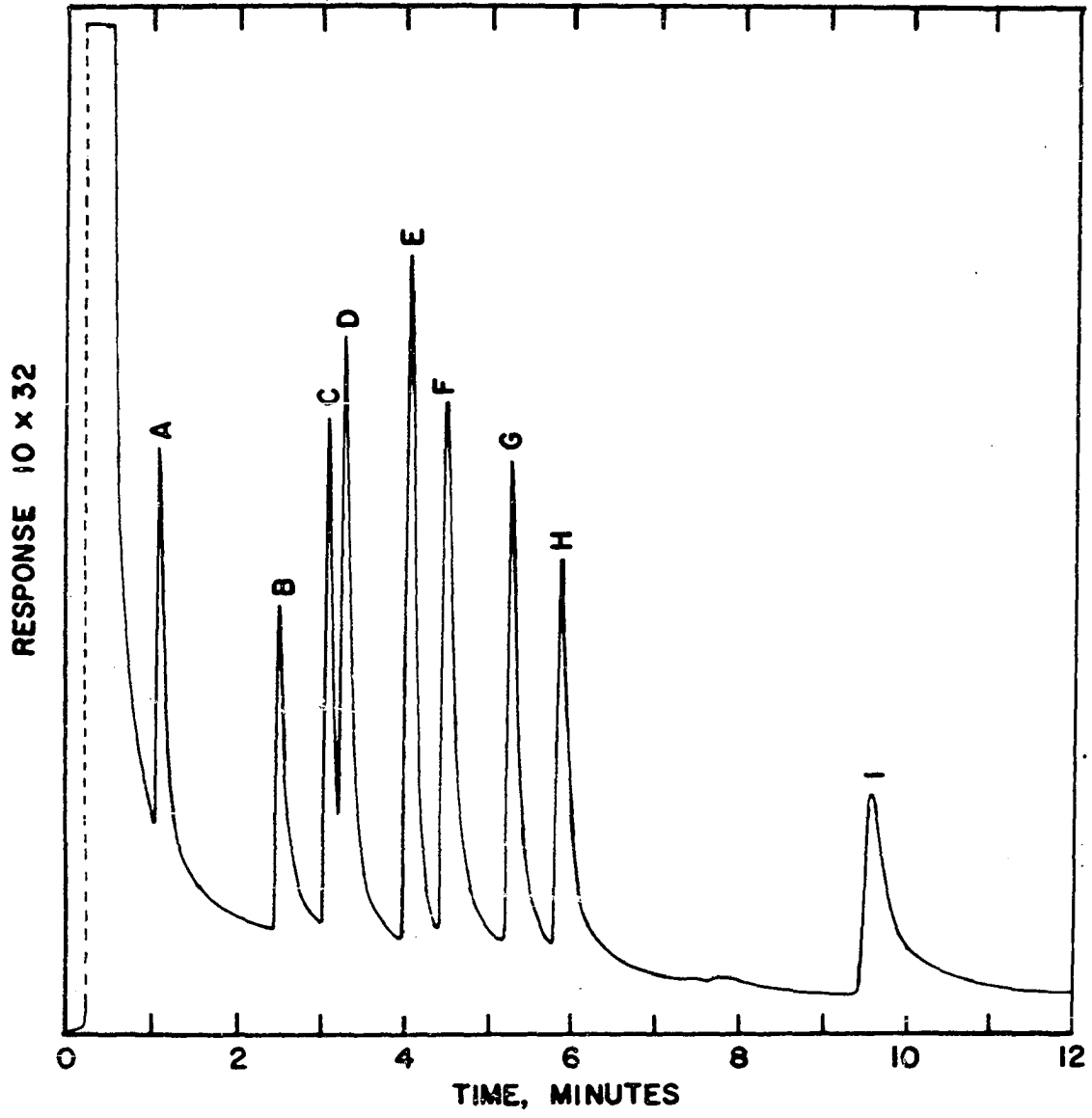

Figure 4. Separation of a standard mixture of phenols on a Tenax GC column. Peak order: (A) solvent impurity; (B) phenol; (C) o-cresol; (D) 3,5-dimethylphenol; (E) 4-chloro-3-methylphenol; (F) 2,4,6-trichlorophenol; (G) 2-naphthol and (H) pentachlorophenol. Separations were obtained on a 1/4 in. x 18 in. SS Tenax GC column. Temperature held at 190 C for one minute then programmed at 10 C/min to 270 C and held at 270 C for 4 min

RESPONSE 10x8

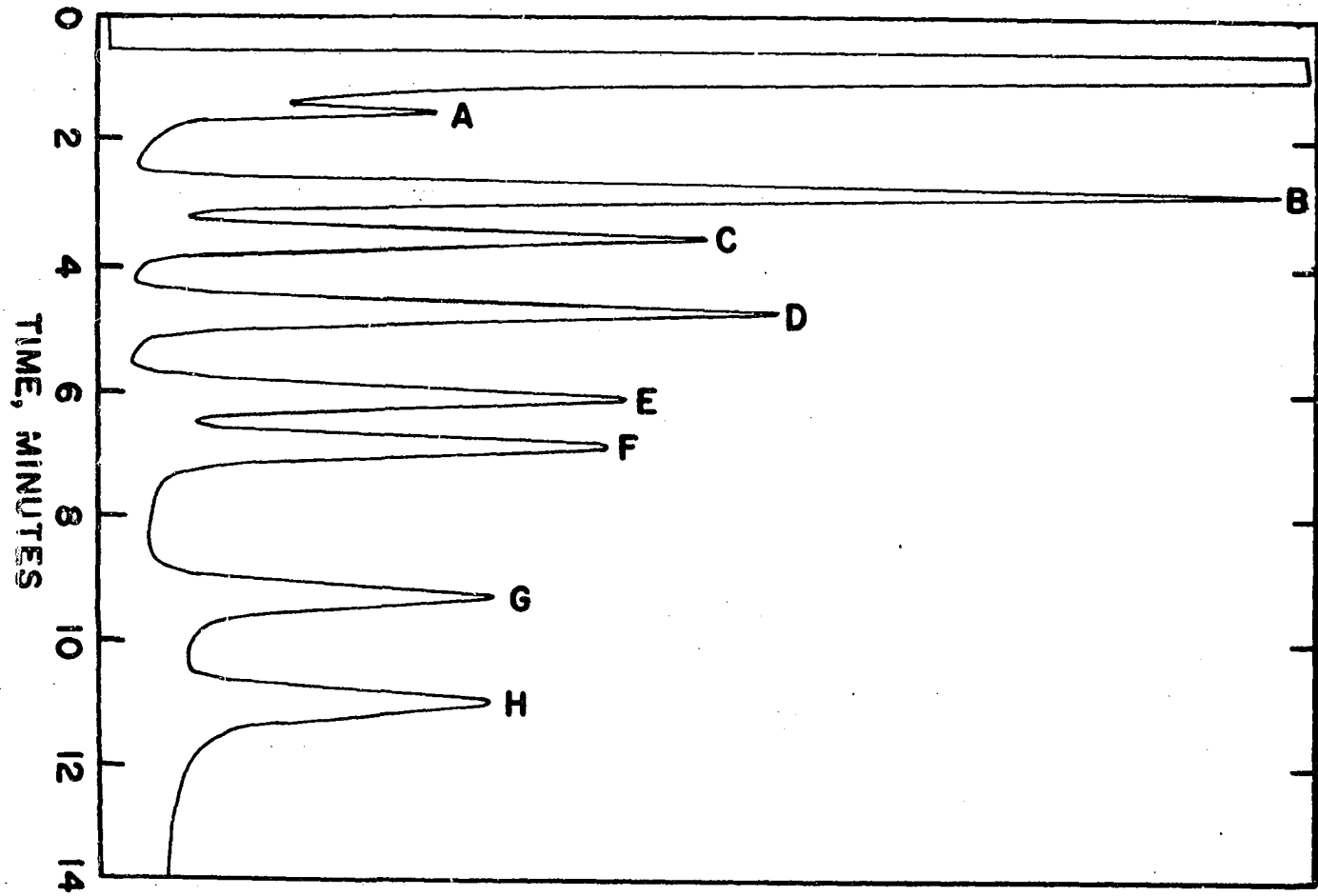

Table 1. Recovery of phenols added to Iowa State University tap water

Compound	Conc, ppb	Recovery, <sup>a</sup> %	Conc, ppb	Recovery, <sup>b</sup> %
Phenol	500	93	25	95
o-Cresol	300	94	15	90
p-Cresol	800	96	40	80
p-Chlorophenol	900	100	45	95
4-Chloro-3-methylphenol	800	100	40	95
2,4,6-Trichlorophenol	1100	102	55	95
Pentachlorophenol	1700	89	85	80
3,5-Dimethylphenol	700	95	35	90
2-Naphthol	500	95	--	--

<sup>a</sup>Using calibration curve; average of 9 analyses except for 2-naphthol.

<sup>b</sup>Using only a single standard, a single analysis is reported the closest 5%.

several other phenols. In this case the gas chromatographic separation was carried out on a Tenax-GC column. The results in the second recovery column show that the method is applicable for analysis of phenols at concentration levels as low as 15 to 85 ppb. These results are for a single run and are given to the nearest 5%.

Other samples were analyzed in which various phenols were added to distilled water or well water. The results were similar to those reported in Table 1.

#### Analysis of wastewater for phenols

Phenols were determined in water samples from an oil refinery-petrochemical plant complex by the chromatographic procedure without modification. The samples undoubtedly contained other organic compounds in addition to phenols. Before analysis the specific phenols present were known, but the chromatographic peaks were identified by comparison of their retention times with those of phenolic standards. The quantitative results showed reasonably good agreement with those obtained by the refinery group using the colorimetric method. The colorimetric method would be expected to give lower results because p-substituted phenols do not react completely with the colorimetric reagent. A summary of the analysis is shown in Table 2.

#### Interference studies

Since copper sulfate is commonly used as a preservative in samples of water taken for determination of phenols,

Table 2. Determination of phenols in refinery and petrochemical plant effluents

Type of phenol	Concentration of phenols found in various streams by chromatographic method, ppm		
	Biologically treated <sup>a</sup> refinery wastewater	Once-thru <sup>b</sup> refinery cooling water	Petrochemical <sup>c</sup> plant process wastewater
Phenol	0.01	0.02	0.36
Cresols	0.22	0.22	0.04
Dimethyl phenols	2.59	0.02	0.40
Trimethyl phenols	0.71	0.03	0.17
Other phenolics	0.31	0.07	0.21
Total phenols	3.83	0.36	1.18
Total phenols by colorimetric method	2.3	0.39	1.03

<sup>a</sup>Major components: 2,5-dimethyl phenol (0.87 ppm), 3,5-dimethyl phenol (0.82 ppm).

<sup>b</sup>Major components: m- and p-cresol (0.20 ppm).

<sup>c</sup>Major components: phenol (0.36 ppm), 3,4-dimethyl phenol (0.32 ppm).

special studies were performed to determine its effect on the procedure. It was found that at concentrations up to 1000 ppm, copper sulfate has no deleterious effect on the determination of phenols.

Inorganic anions in water, such as bicarbonate, can compete effectively with phenolate ions for exchange sites unless sufficient excess resin capacity is present. The recommended 0.25 in. by 6 in. columns have enough capacity to allow for very high concentrations of other anions.

A number of neutral organic compounds were retained by the A-26 resin. However none of these compounds affected the recovery of phenols. They can be eluted from the resin by alkaline methanol prior to elution of phenols and thus do not interfere with the gas chromatographic determination of phenols.

Carboxylic acids also caused no interference with the recovery of phenols using the recommended procedure, but can interfere with the gas chromatographic determination of phenols on OV-17 columns by overlapping the phenols and cresol peaks. When a Tenax-GC column was used, acids elute well before phenols. A summary of the interference studies is shown in Table 3.



Table 3. Interference study. Samples contained approximately 1 ppm each of several phenols and 20 ppm of each added compound.

Added compound	Result
Hexyl alcohol	
Benzyl alcohol	
2-Phenoseyethanol	No interference
Methyl cellosolve	
Naphthalene	~2 to 3% recovery without MeOH wash
Acenaphthene	No interference after MeOH wash
Hexanoic acid	
Octanoic acid	Interference with phenol and cresols on OV-17
Butanoic acid	

## CONCENTRATION AND DETERMINATION OF TRACE ORGANICS

Organic constituents in water may be naturally produced within the water body, such as plankton waste products, or derived from outside the water body, such as leaves detritus or by man-made waste products (46).

The nature and concentrations of organic pollutants in drinking water is a matter of great concern, therefore it is vital that reliable analytical methods of water analysis be developed. The extremely low concentration (usually less than one ppb) of gas chromatographable organic pollutants in drinking water requires an efficient concentration method prior to the chemical separation by gas chromatography or other chromatographic techniques.

### Review of Related Work

Only within the last few years instrumentation and techniques sophisticated enough to measure very small quantities of pollutants have been applied to drinking water. With the aid of modern analytical techniques such as gas chromatography-mass spectrometry (GC/MS), many types of organic contaminants have been detected in drinking water. While the GC/MS is almost exclusively applied for qualitative and quantitative analysis of organic mixtures, many other principles and analytical techniques have been used for extraction and concentration of organic pollutants from water.

The literature of the last several years abounds with methods for the analysis of water for organics. This reflects the urgent interests among the scientists. The following review of literature will be very selective and will discuss only some of the major analytical approaches for concentration and determination of trace organic impurities from water prior to their separation and determination by gas chromatography. Among these are solvent extraction, gas stripping, direct aqueous-injection and resin sorption.

Solvent extraction is the best documented and most widely used. The most common and simple extraction of organic compounds from water is carried out by shaking with a water immiscible solvent and the organic compounds are concentrated by solvent removal. The procedure has been applied successfully to water analysis, even at extreme trace concentration when specific detection was possible (47,48), and at concentration levels above one ppb (49). Goldberg et al. (50) devised a continuous extraction apparatus for concentration of organic solutes from water. A concentration factor of up to  $10^5$  was obtained with this technique but the extraction efficiency was dependent upon the dipole moment difference between the solute and solvent. Austern et al. (51) extracted water samples with Freon and concentrated the organics in a Kuderna-Danish apparatus. The method successfully analyzed the spiked wastewater in ppb. McAuliffe (52) used nitrogen or helium to extract organic solutes from water samples in a glass syringe. Then

an aliquot of the gas was injected into a gas chromatograph and the organics were separated and determined. The method works favorably for highly volatile organic compounds of low water solubility. Recently Grob (53) and his co-workers extracted 1 liter of water sample with only 200  $\mu\text{l}$  of pentane. This was carefully drawn off with a syringe and then shaken to separate the small amount of water that accompanied the pentane. The pentane extract was evaporated to 3  $\mu\text{l}$  if more sensitivity was required, and this entire amount was injected into a gas chromatograph equipped with a capillary column. The efficiency of extraction of the method decreased with increasing volatility.

Gas stripping is a special application of head space analysis. Zlatkis termed a technique "head space" analysis in which an inert gas is bubbled through an aqueous sample for a given period of time. The gas then passes through a sorbing material that retains the volatile organic compounds but allows most of the water vapor to pass through. Zlatkis and his co-workers (54-59) applied this technique successfully to analyze volatile compounds in air and metabolites in urine, serum, and plasma. Swinnerton and Linnenbom (60) were first to determine  $C_1$  to  $C_4$  hydrocarbons by stripping them from water with helium. Swinnerton and Lamontagne (61) have applied this technique to analyze the water samples from oceanic environment for low molecular weight hydrocarbons. Grob and his co-worker

(62,63) developed a unique stripping system in which a small volume of gas to transfer organic impurities from water at room temperature to a charcoal filter in a hermetically closed loop. The organics were eluted with a small amount of organic solvent and determined by capillary-column gas chromatography. Bellar and Lichtenberg (64) used nitrogen as the purging gas and Tenax-GC as the sorbent. Gas stripping has become very popular and works well for compounds that are volatile and sparingly soluble in water. Much of the work published using this technique has been mostly qualitative, so that the quantitative aspect of the method is not clear at present time.

Direct aqueous-injection gas chromatography (65-69) has been used to analyze the waters for organic compounds, although this procedure is generally useful for analysis of industrial effluents at concentration levels above 1 ppm.

Activated carbon has been used for more than a decade for separating organic compounds from surface waters and certain industrial effluents (70,71,72) but the method does not separate quantitatively the total organic contents of a water sample. It can be used to advantages for screening purposes as well as for monitoring industrial waste effluents.

The XAD-2 resin sorption method (42,73,74,75) is probably the most reliable and thoroughly tested method for determining trace organic pollutants in drinking water. However, the solvent evaporation step in this procedure results in a partial or complete loss of volatile compounds. In addition, the

aliquot (2  $\mu$ l) of the ether concentrate taken for gas chromatographic analysis is only a small fraction (1/500) of the actual concentration. To avoid these drawbacks a procedure has been developed in which organic compounds that are sorbed on a resin are thermally transferred to a second sorption column and then to an analytical column for analysis.

A thermal desorption method was proposed earlier by Mieure and Dietrich (76) but they did not develop the method very much. They found that interstitial water often caused the FID flame to be extinguished. In the present method this difficulty is avoided by first desorbing the sorbed organic compounds from a column containing XAD-2 onto a Tenax-GC column. This eliminates virtually all of the water entrained in the XAD-2 column.

Ligon and Johnson (77) recently described a device to thermally transfer volatiles sorbed on a substrate from the substrate to a gas chromatograph-mass spectrometer. In the present method, the thermal device is the regular heated injection port of the gas chromatograph with slight modification as described in the experimental section.

## Experimental

### Apparatus and reagents

Gas chromatograph      A Hewlett-Packard Model 5756B gas chromatograph equipped with a flash vaporization inlet, a linear temperature programmer, thermal conductivity detector,

dual flame ionization detector and  $^{63}\text{Ni}$  electron capture detector, was used for determining neutral organic compounds. The injection port was modified to accommodate the glass sorption columns. The injection port was made by silver-soldered a 1/8 in. Swagelok union onto a 5 1/2 in. by 1/4 in. o.d. stainless steel tubing. It replaced the flash vaporization inlet in use. All chromatograms were recorded on a Hewlett-Packard Model 7128A strip chart recorder.

Mini-sampler Figure 5 is a schematic diagram of a mini-sampler used in this work. A mini-sampler consists of a 20-ml glass syringe connected to a XAD-2 sorption column by a specially machined Kel-F coupler which is shown in Figure 6.

Reagents The organic chemical used to prepare standard water samples were purchased from Chem Services Inc., 851 Lincoln Avenue, West Chester, Pennsylvania and were used as received. All other solvents and chemicals were analytical grade.

Water used to prepare the synthetic water samples was triple-distilled over potassium permanganate.

Resins XAD-2 resin was obtained from Rohm and Haas, 500 Richmond Street, Philadelphia, Pennsylvania. This resin is a styrene-divinylbenzene co-polymer which has the macro-reticular characteristics essential for high sorption capacity. The active surface area is  $300 \text{ m}^2$  per gram of resin and the pore diameter is about  $90 \text{ \AA}$ . The resin as received from the supplier was ground to small particles in a Model 4-E Quaker

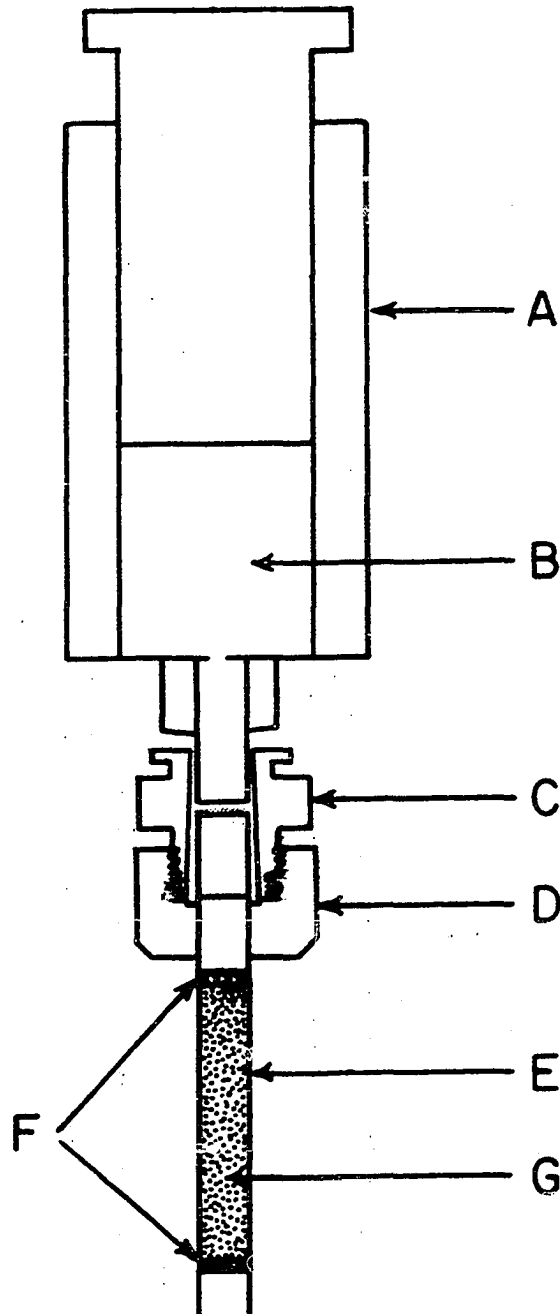

Figure 5. Mini-sampler for small water volumes. (A) 20 ml glass hypodermic syringe; (B) water sample, (C) coupler for attaching mini-column (E) to the syringe; (D) 1/8 in. Swagelok nut; (E) 2 mm i.d. Pyrex tube; (F) glass wool plugs; (G) 80 mg of 60-80 mesh XAD-2



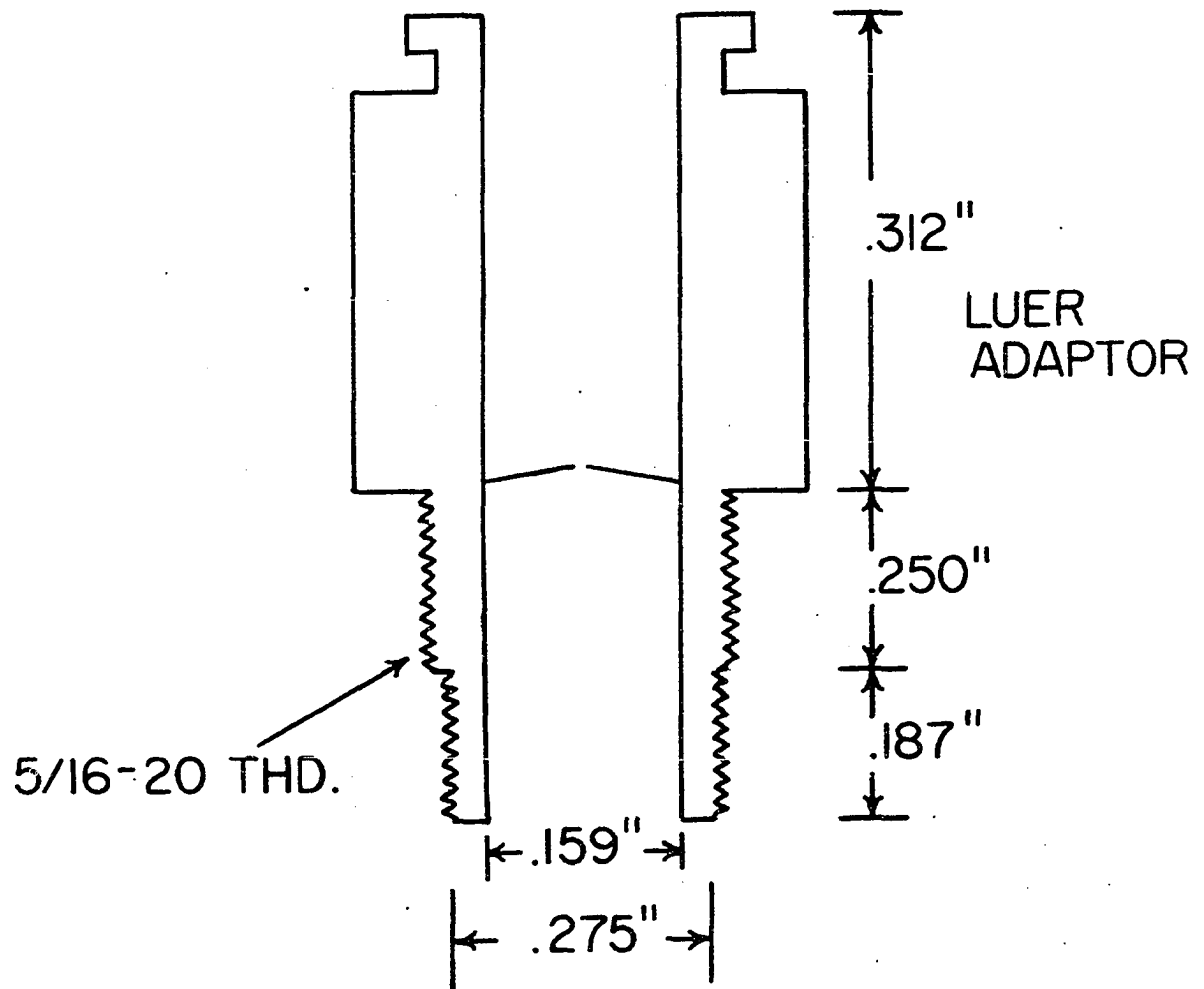

Figure 6. Kel-F coupler

City mill and sieved dry. Only the 60-80 mesh portion was then purified by sequential solvent extractions with methanol, acetonitrile and ethyl ether in a Soxhlet extractor for eight hours per solvent. The resin was then stored in a glass stoppered bottle to maintain its high purity.

Tenax-GC, 60-80 mesh, was purchased from Applied Sciences Laboratories, Inc., State College, Pennsylvania and was used without further purification. This resin is also a porous polymer based on 2,6-diphenyl-p-phenylene oxide. This resin has relatively low surface area and a high maximum operating temperature of 375 C.

#### Techniques and procedures

Sorption columns preparation and conditioning Sorption columns were prepared from 2 mm i.d. Pyrex glass columns cut into 10 cm in length and fire-polished at both ends. A glass wool plug was inserted into each column approximately 1 cm from one end. Each column was then filled with 7 cm of either XAD-2 or Tenax-GC and tapped gently to compact the polymeric sorbents. Each column was plugged with glass wool at the other end to hold the sorbent in place.

The XAD-2 sorption columns were conditioned by thermal desorption at 240 C and repetitive blank runs until a low, tolerable background was achieved. A blank run consisted of wetting the resin with triple-distilled water and following step 2 and 3 of the analytical procedure for recovery efficiency studies.

The Tenax-GC sorption columns required only a simple conditioning for an hour at 275 C under helium flow to achieve a tolerable background.

#### Packing and conditioning of gas chromatographic columns

All columns were washed with methylene chloride, acetone and ethanol and air dried before packing. The dried packing, Tenax-GC or 5% OV-17 on Chromosorb W AW DMCS, 80-100 mesh, was poured into the columns and compacted by agitation from a Burgess Vibro-graver. The column ends were plugged with glass wool.

OV-17 GC column was conditioned at 240 C for 24 hours with a helium flow of 25 ml/min.

Tenax-GC GC column was conditioned for one hour at room temperature with a helium flow of 15 ml/min; then the temperature was programmed to 240 C at 10 C/min and held the column at this temperature for two hours and the column was allowed to cool to room temperature.

#### Analytical procedure-recovery efficiency studies

1. Sampling. A 15-ml (or larger) synthetic water sample was forced through the XAD-2 sorption column using the mini-sampler with hand pressure (it took about three minutes). Then the residual water was forced as much as possible from the column using 20 ml of air. The sorption column was capped at both ends unless the analysis was to continue without delay.
2. Thermal desorption. The XAD-2 sorption column was

placed in a heated zone maintained at 220 C with a helium flow of 50 ml/min into the XAD-2 column and out the Tenax-GC column which was held at approximately 45 C. Thermal desorption was continued for 15 min or until the Tenax-GC column was visibly dry.

3. Separation. The two sorption columns were disconnected. The Tenax-GC sorption column was then placed into the modified GC injection port held at 220 C and the organic solutes were thermally desorbed with a helium flow of 20 ml/min and concentrated on the first few milliliters of the analytical column which was at room temperature. The transfer of the organic solutes took about 10 min. The organic solutes were then separated using following operating parameters:

Liquid Phase: 5% OV-17 or Tenax-GC

Solid Phase: Chromosorb W AW DMCS or Tenax-GC

Column Dimension: 6 ft by 0.125 in. o.d. (OV-17) or

4 ft by 0.125 in. o.d. (Tenax-GC)

Detector: FID

Helium Flow: 24 ml/min

Temperature:

Injection port: 220 C

Column: Initial 30 C, followed by 20 C/min increase  
to 200 C and final hold of ten minutes

4. Quantitation. A 2- to 5- $\mu$ l sample of standard organic solution in methanol was injected through a 220 C heated zone and the organic solutes trapped on the Tenax-GC sorption

column which was at room temperature or slightly above. The organic solutes were desorbed and chromatographed as in Step 3 of the analytical procedure. The peak heights of the sample and standard peaks were compared to calculate the recovery of the sample constituents. Figure 7 shows chromatograms of a blank, standard and spiked sample.

Analytical procedure-real water samples      Samples of finished water from nearby cities were collected in 300-ml glass-stoppered bottles. The collected water samples were analyzed the following day using the described method without modification.

## Results and Discussion

### Development of analytical method

In developing the analytical method, the various approaches were studied to test their applicability and feasibility. Three approaches, namely direct aqueous-injection, single sorption column and double sorption column will be discussed in the following section.

Direct aqueous-injection gas chromatography      Two different analytical methods using this technique will be briefly described.

Determination of trace organics      Direct aqueous-injection used to be considered as something that was best avoided in gas chromatography because water tends to be adsorbed on many types of solid supports, resulting in large

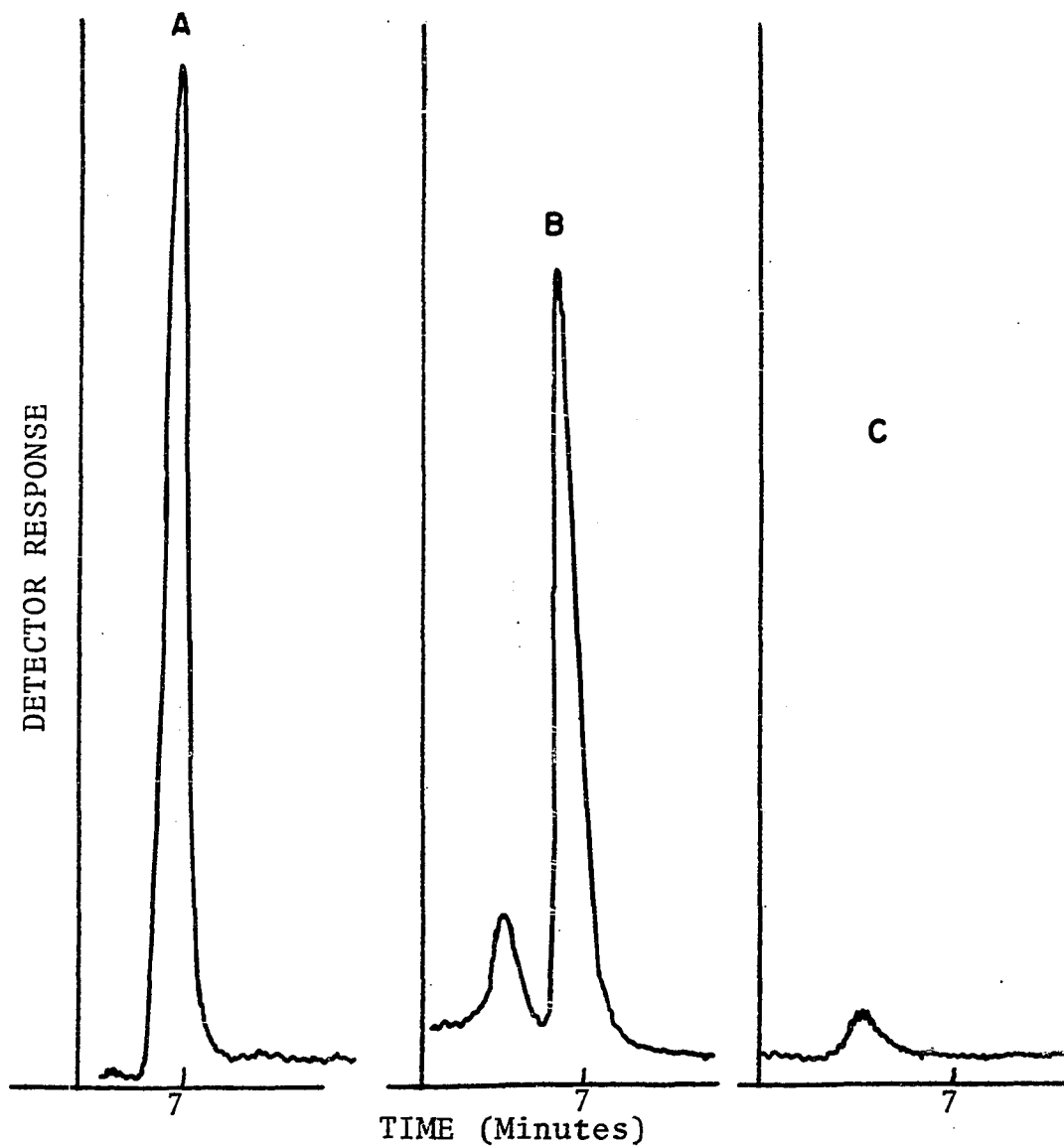

Figure 7. Recovery of heptane: (A) heptane standard, (B) water sample spiked with heptane, and (C) blank run with unspiked water sample

tailed peaks. Water also can cause some stationary liquid phases to hydrolyze or bleed. However, porous polymers have been developed that will tolerate small injections of aqueous samples. In principle direct aqueous-injection is attractive because it is probably the simplest way to get acetone sample into the gas chromatograph. A limiting factor of this method is that very small water samples (1 to 3  $\mu\text{l}$ ) must be used. To avoid this drawback, a procedure has been traced in which a 4-port switching valve was placed between a Tenax-GC pre-column (18 in. by 0.25 in. o.d.) and a Tenax-GC analytical column (16 in. by 0.125 in. o.d.). With the injection port at 200 C and pre-column at room temperature, a 50- $\mu\text{l}$  water sample was injected. After a 2-min wait, another 50- $\mu\text{l}$  sample can be injected if desired. As many as six such injections have been made. There was an additional 5-min wait after the final injection to allow time for the rest of the water vapor to pass through the pre-column and through the vent. Then the switching valve was changed so that two columns were connected together and the oven temperature programmed up to separate the organics. A typical chromatogram obtained from a spiked water sample using the described method is shown in Figure 8.

Essentially quantitative recoveries were obtained for analysis of spiked water samples containing 1.88 ppm of acetone, 9.0 ppm benzaldehyde and 200 ppb benzene; and on a 300- $\mu\text{l}$  sample containing 3.00 ppb carbon tetrachloride using electron capture detector. Although this procedure is simple and

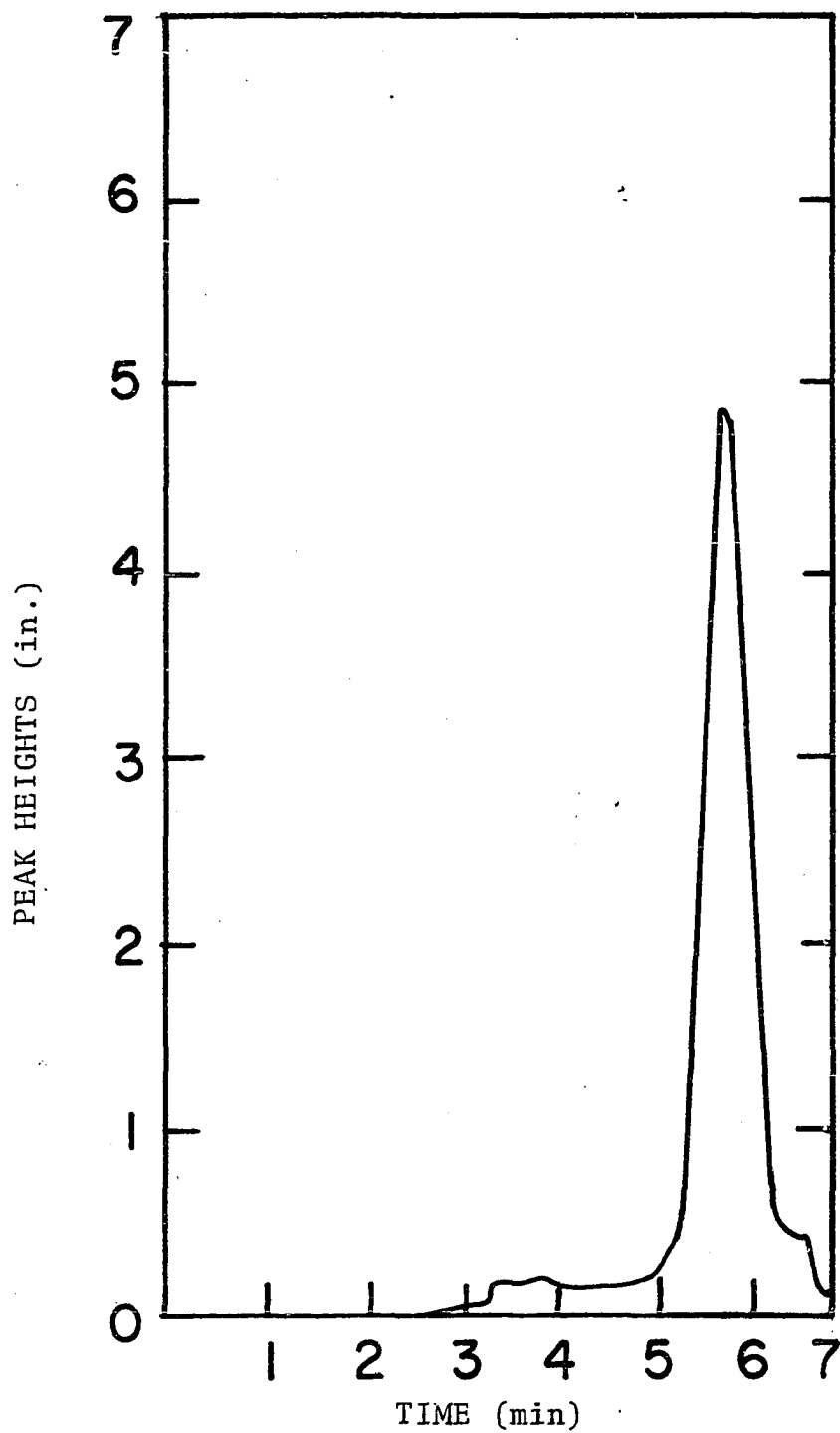

Figure 8. A chromatogram obtained using direct aqueous-injection with benzene as the model compound



rapid, it is not sensitive enough for most analysis of drinking water for organic compounds. No further experiments were tried. This method should be valuable for analysis of wastewaters where the concentrations are high enough.

Determination of traces of water      The determination of traces of water is one of the most important, and at the same time most difficult, problems of trace analysis since water is universally present and being highly polar it adheres to all surfaces (78). The most popular method that can still be used in the majority of cases is the Karl Fischer method (79) which is only applicable at milligram level and cannot be used in systems containing interferences such as ketones, aldehydes, most acids, oxidizing agents, reducing agents and free halogens. In order to overcome some drawbacks, there have been many attempts to determine traces of water by gas chromatography since 1959 (80). However, early applications met with difficulties because water peaks were unsymmetrical and tailed badly, and water tended to be adsorbed strongly on the supports and stationary phases. Improvements have been made since the introduction of the Porapak series by Hollis and Hayes (81) in 1966. Porapaks have been used to determine traces of water in hydrocarbons, alcohols, glycol, chlorinated hydrocarbons, ammonia and acids. Neuman (82) reported excellent results for the direct determination of water with Porapak R. A limit of detection of 1 ppm of water was obtained with a thermal conductivity detector. However, Gough (83) and his

co-worker pointed out that characteristics of Porapak vary between batches and errors run as high as 20% at low concentration. For quantitative work a porous polymer must be chosen with care and the highest practical column temperature is necessary to reduce adsorption of water on the polymer.

A new porous polymer based on 2,6-diphenyl-p-phenylene oxide was introduced by AKZO Research Laboratory and has been used in various areas (84). During the development of direct aqueous-injection gas chromatography for determining organics in water, it was found that Tenax-GC column is much different from Porapak because it is so hydrophobic that even at lower temperatures (35 C) the water peaks are symmetrical. In addition, Tenax-GC has relatively longer retention times for most organic solvents.

A procedure for determining trace amounts of water in organic solvents was designed and the following limited experiments were performed to test its applicability. The procedure is a direct determination of traces of water with a thermal conductivity detector (TC). Water is separated from organic solvents using following GC operating parameters:

Packing: Tenax-GC, 60-80 mesh

Column dimension: 16 in. by 0.125 in. o.d.

Detector: TC

Helium flow: 30 ml/min

Temperature:

Injection port: 150 C

Column: Initial 30 C for 1 min, followed by quickly heating to 150 C if required to backflush the organic solvents

Detector: 200 C

Traces of water have been determined in different solvents using the described method. In each case, 4  $\mu$ l of organic solvent was injected and following water contents were found: acetone 0.55%, ethyl acetate 0.13% and benzaldehyde, 0.2%. Only traces of water were found in absolute methanol but the separation of water and methanol is very marginal. Water has a retention time of 0.4 min and methanol has a retention time of 0.48 min of the Tenax-GC column used in this procedure.

A calibration curve, which is shown in Figure 9, was obtained to show that a linear dependence of peak heights on concentrations of water can be established. In this experiment standard solutions of water were prepared in methyl cellosolve. Methyl cellosolve was not dried before spiking and it contained 0.03% of water.

With limited data, it seems possible to determine trace amounts of water in organic solvents by the described method. The sensitivity can be increased with larger sample injections through a backflushing valve system.

Single sorption column In this method, a water sample was passed through the small sorption column containing XAD-2 and the sorbed organic compounds were thermally desorbed onto

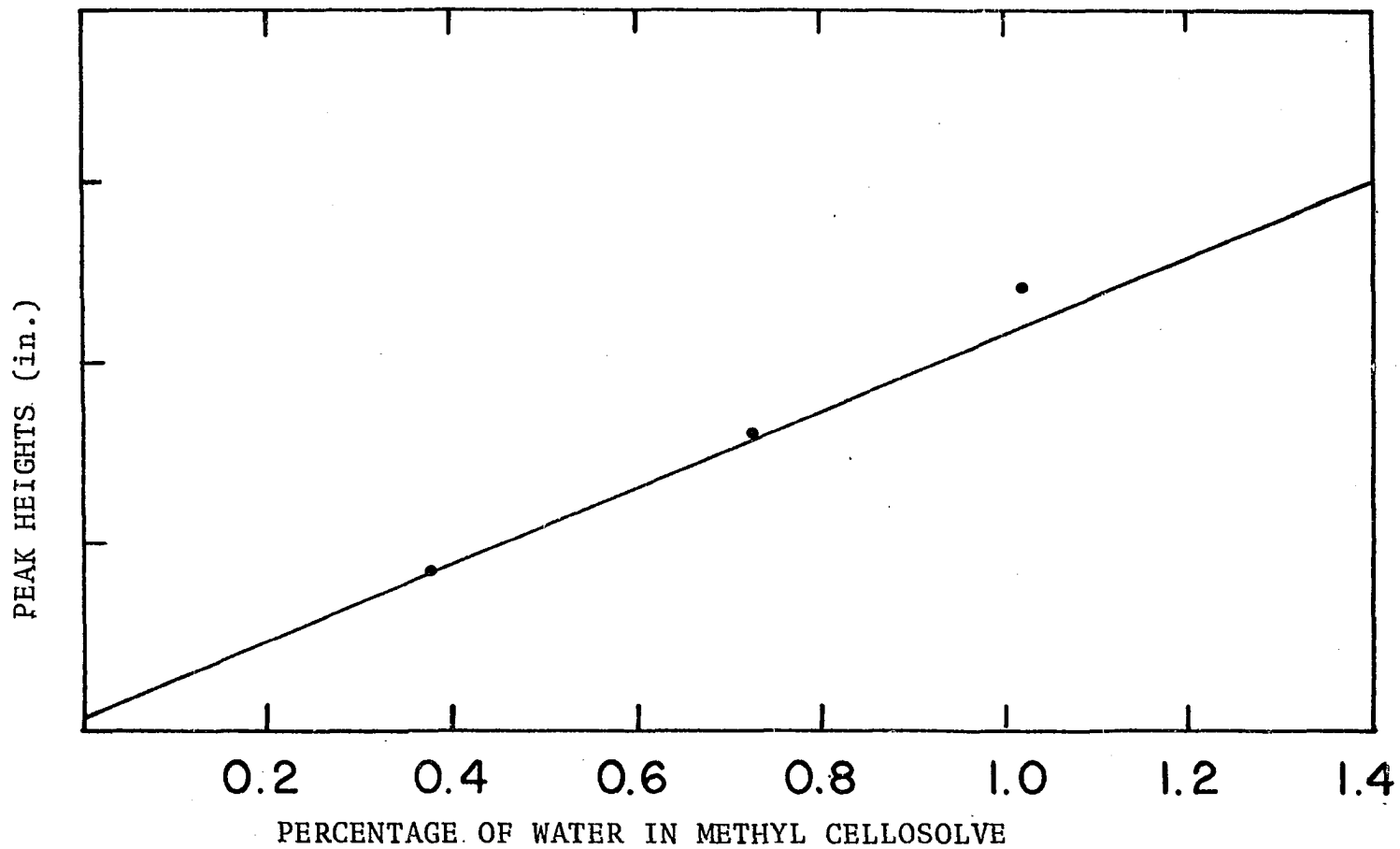

Figure 9. Linear relationship between the response of the TC detector and the concentration of water in methyl cellosolve

a 18 in. by 0.25 in. o.d. gas chromatographic column packed with Tenax-GC at room temperature. A switching valve in the gas chromatograph allowed water to pass through the column to vent while concentrating organic solutes on the Tenax-GC. After a few minutes the valve was switched to connect the Tenax-GC column to a second 16 in. by 0.125 in. o.d. Tenax-GC column. The oven temperature program was started and the organic solutes were separated. A typical chromatogram obtained using the described method is shown in Figure 10. Although this method works satisfactorily for volatile compounds, it has two important limitations: (1) the recovery of less volatile compounds (e.g. naphthalene) is not reproducible, and (2) the analytical column is limited to Tenax-GC or some similar hydrophobic packings. Furthermore, the peaks are very broad and it has limited resolving power.

Other sorbents were also studied but they all are inferior to XAD-2. XAD-7 and XAD-8 did not give any usable data because they gave consistently high blanks and difficulties were encountered in pushing the aqueous solution through. Since Tenax-GC gave consistently much lower recovery results (10-20% recovery) than recovery results obtained using XAD-2, it proved that Tenax-GC is not a good sorbent for extracting organics from aqueous solution.

Double sorption columns      In this approach, organic impurities are first isolated by sorption on a mini-column containing XAD-2. The sorbed organics are then thermally

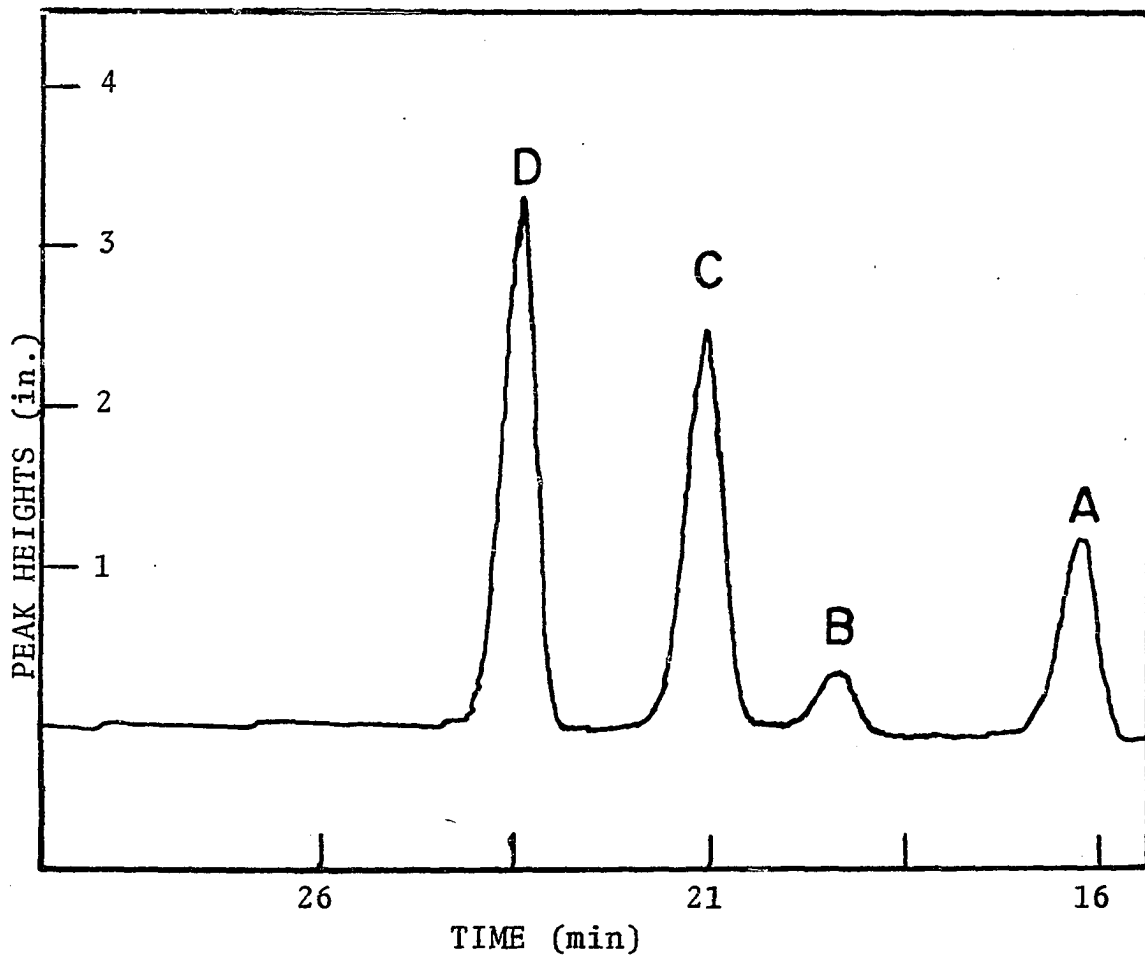

Figure 10. A chromatogram obtained using single sorption column: (A) acetone, (B) chloroform, (C) benzene, (D) toluene  
GC conditions: initial hold at room temperature for 4 min, followed by 8 C/min increase to 170 C and final hold of 4 min

transferred onto a second mini-column containing Tenax-GC. This eliminates virtually all of the water entrained in XAD-2 column and quantitatively transfers the sorbed organics. As a result of this step, gas chromatographic columns other than Tenax-GC can be used. This method also gives satisfactory results for a variety of organic compounds. A typical chromatogram obtained using the described method is shown in Figure 11. Peak shapes are improved.

#### Recovery studies

Organic compounds representing eight different classes of compounds and covering a wide volatility range were added to water (3 to 200 ppb) and used to test the resin extraction-thermal desorption procedure. The recoveries obtained are summarized in Tables 4 and 5. The average recovery was 83%. However, if the results from three polar compounds known to be incompletely retained by the XAD-2 (acetone, butanol, pentanol) are discarded, the average recovery is 88%. The recovery results compare very well with those obtained with larger columns of water and the macro-samples (42). However, the current values include many results for volatile compounds that could not be measured with the macro-sampler. The only unusual value is the high efficiency for alkanes. Lower recovery efficiencies are always observed for alkanes when the macro-sampler is used. No explanation of this discrepancy is available now.

The recoveries of carboxylic acids were not reproducible.

Figure 11. A chromatogram obtained using double sorption columns  
GC conditions: 5 min hold at room temperature, followed by quick heating to 90 C and hold at that temperature for 1 min, then 20 C/min increase to 205 C and final hold for 8 min



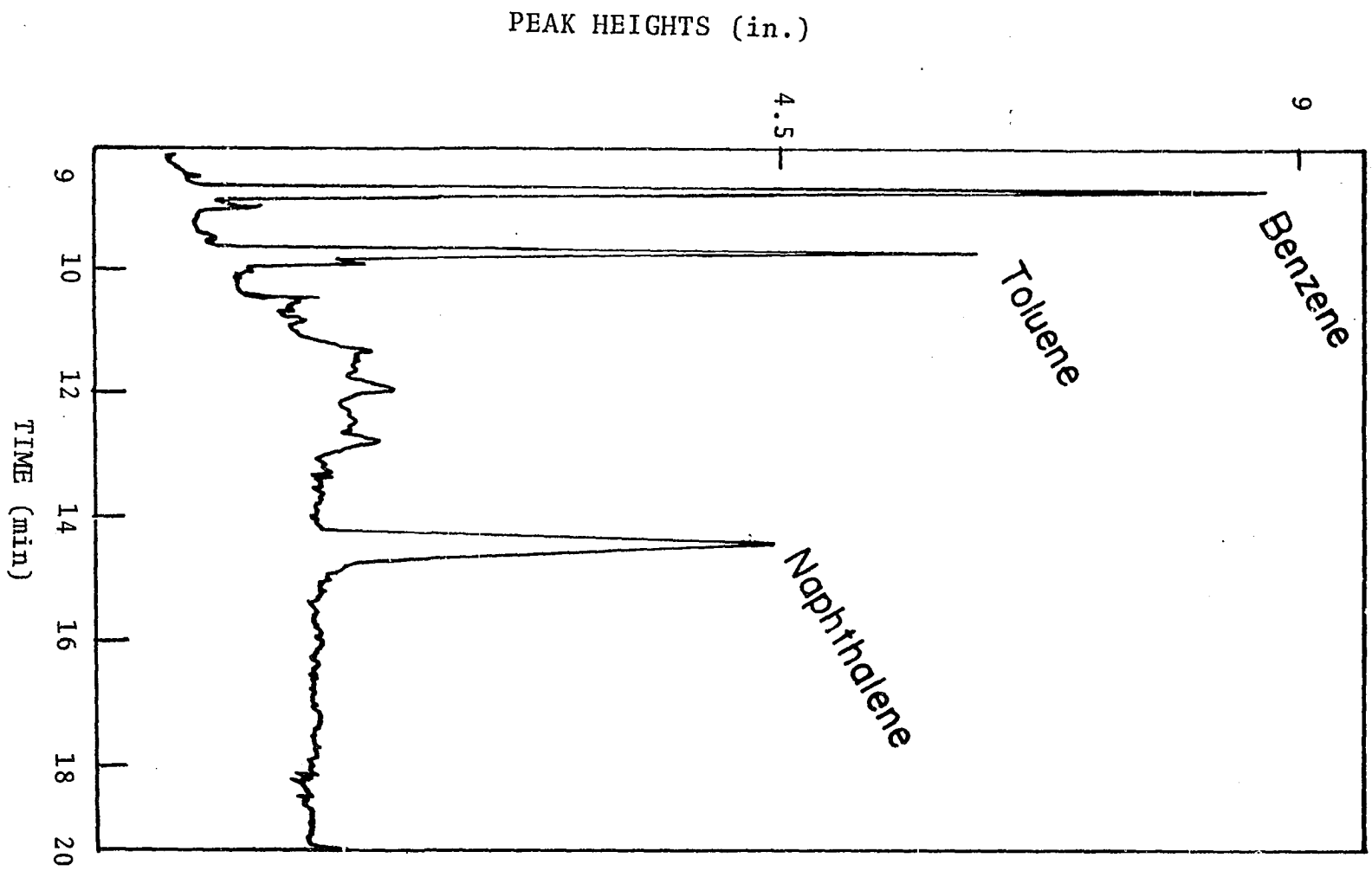

Table 4. Overall recovery efficiency of resin extraction-thermal desorption (RETD) method of analysis on XAD-2 for organics in water at the 3 ppb to 100 ppb level<sup>a</sup>

Compounds	Recovery efficiency %	Compounds	Recovery efficiency %
<u>Alkanes</u>		<u>Polynuclear aromatics</u>	
Octane	88	Naphthalene	98
Heptane	81	2-Methylnaphthalene	97
Tridecane	90		
<u>Alkyl benzenes</u>		<u>Chloro benzenes</u>	
Benzene	90	Chlorobenzene	90
Toluene	97	o-Dichlorobenzene	82
o-Xylene	90		
Cumene	82	<u>Ketones</u>	
<u>Ethers</u>		Acetone	55
Hexyl	80	2-Octanone	83
Benzyl	70	Undecanone	86
		Acetophenone	92
<u>Esters</u>		<u>Alcohols</u>	
Benzyl acetate	95	1-Butanol	<40
Methyl decanoate	88	1-Pentanol	<40
Methyl hexanoate	86	1-Octanol	85
		1-Decanol	84
<u>Haloforms<sup>b</sup></u>		<u>Phenols and acids</u>	
Chloroform	87	No quantitative results	
Bromodichloromethane	95		

<sup>a</sup>3 ppb corresponds to 3 µg/l.

<sup>b</sup>Chlorinated methanes were tested at a concentration of 200 ppb in water.

Table 5. Recovery efficiency for RETD method by the classes of compounds

Compound type	No.	Ave. %
Alkanes + alcohols	7	73
Ethers + esters	5	84
Alkylbenzenes + PNA's	6	92
Halocarbons + ketones	<u>8</u>	<u>84</u>
	Total = 26	Wt. ave.=83

This is believed to be due to the difficulty of direct analysis of acids by gas chromatography. A selective method for concentration of acids with subsequent derivitization of acids for gas chromatography would be more desirable. The recoveries for phenols varies from 40% to 90%. These inconsistent results are probably due to high affinity of Tenax-GC for phenols.

Despite some limitations, however, no other single procedure will give satisfactory results for water samples containing both volatile compounds (chloroform, benzene, etc.) and less volatile substances such as naphthalene and acetophenone.

#### Method parameters

Desorption temperature      The high percentage recoveries in Table 4 indicate that 220 C for the first thermal desorption step from XAD-2 onto Tenax-GC is adequate for total desorption, but some test results indicate that the second thermal temperature is critical for real water samples. A standard solution containing 0.8  $\mu\text{g}$  each of toluene, benzene, acetophenone, 2-octanone and octane in 2  $\mu\text{l}$  of methanol was injected through a heated zone, trapped on the Tenax-GC columns, desorbed at three different temperatures and separated in a manner similar to that used before. The chromatograms of these tests are shown in Figures 12, 13, and 14. These chromatograms, show that lower temperatures have little effect on

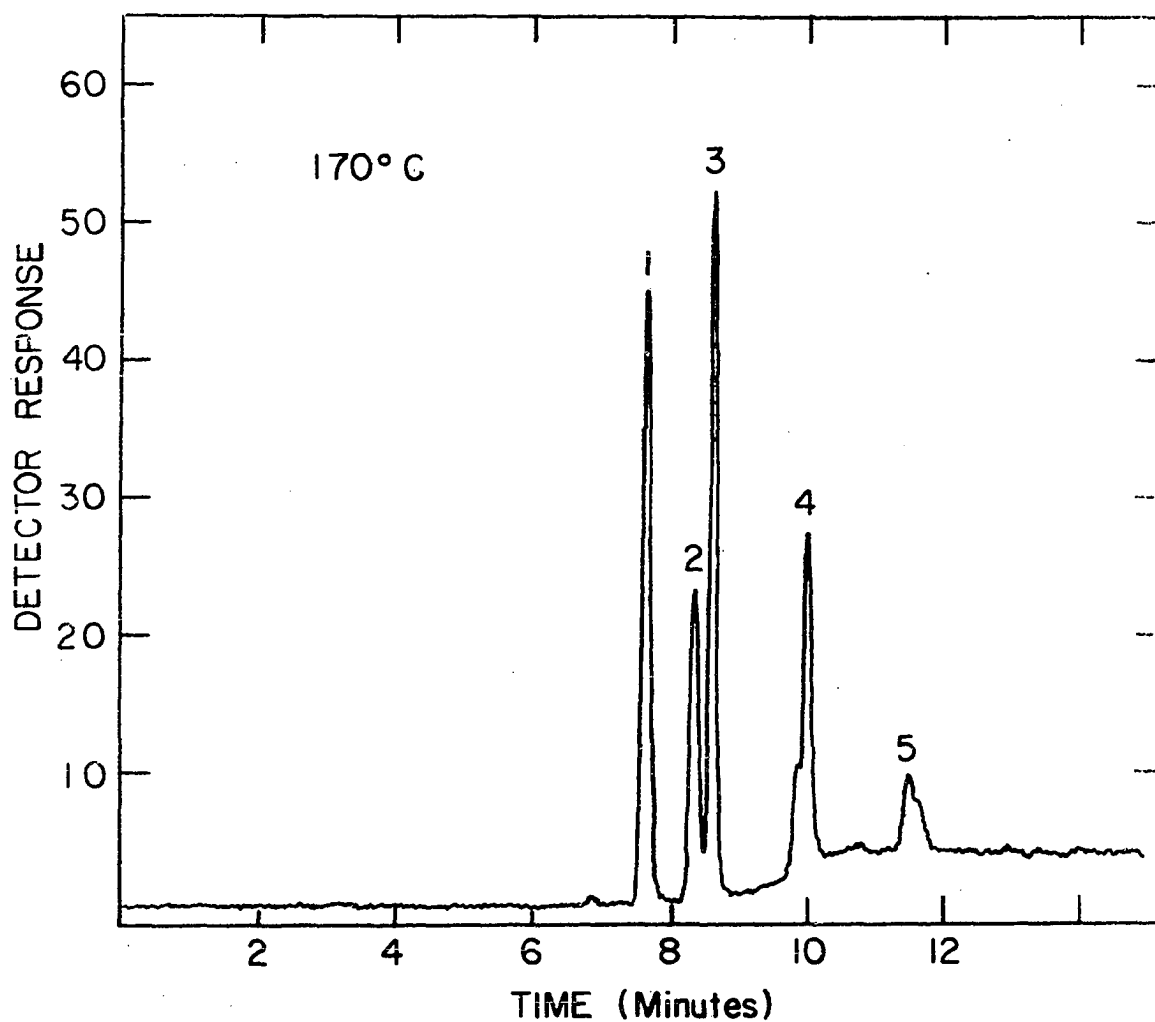

Figure 12. Gas chromatogram of model compounds in spiked water sample using following parameters: Desorption temperature 170 C. Column temperature: initial 30 C, followed by 20 C/min increase to 200 C and final hold of 5 min. (1) benzene, (2) octane, (3) toluene, (4) 2-octanone, (5) acetophenone

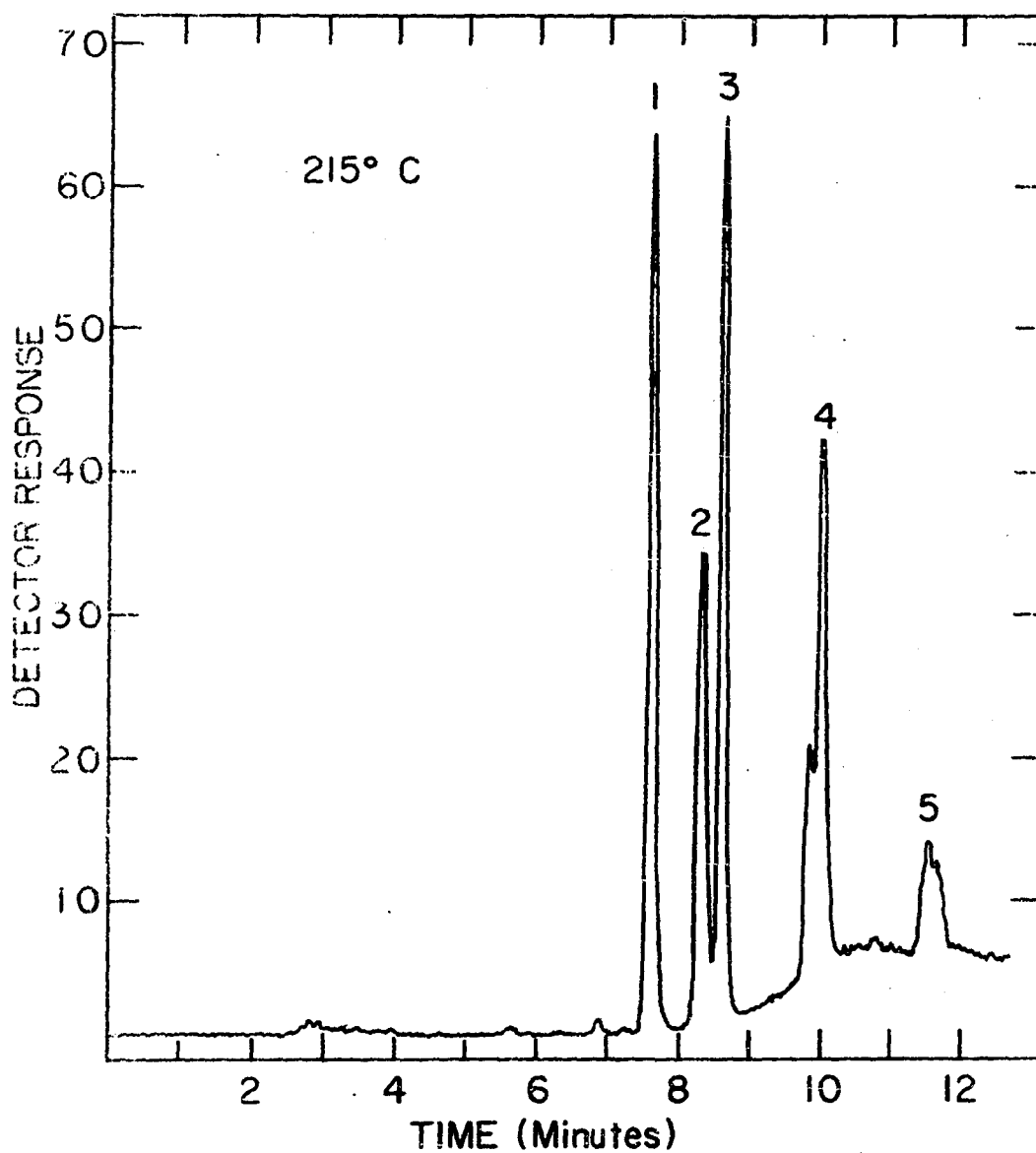

Figure 13. Gas chromatogram of model compounds in spiked water. Same conditions as in Figure 12 except desorption temperature: 215 C

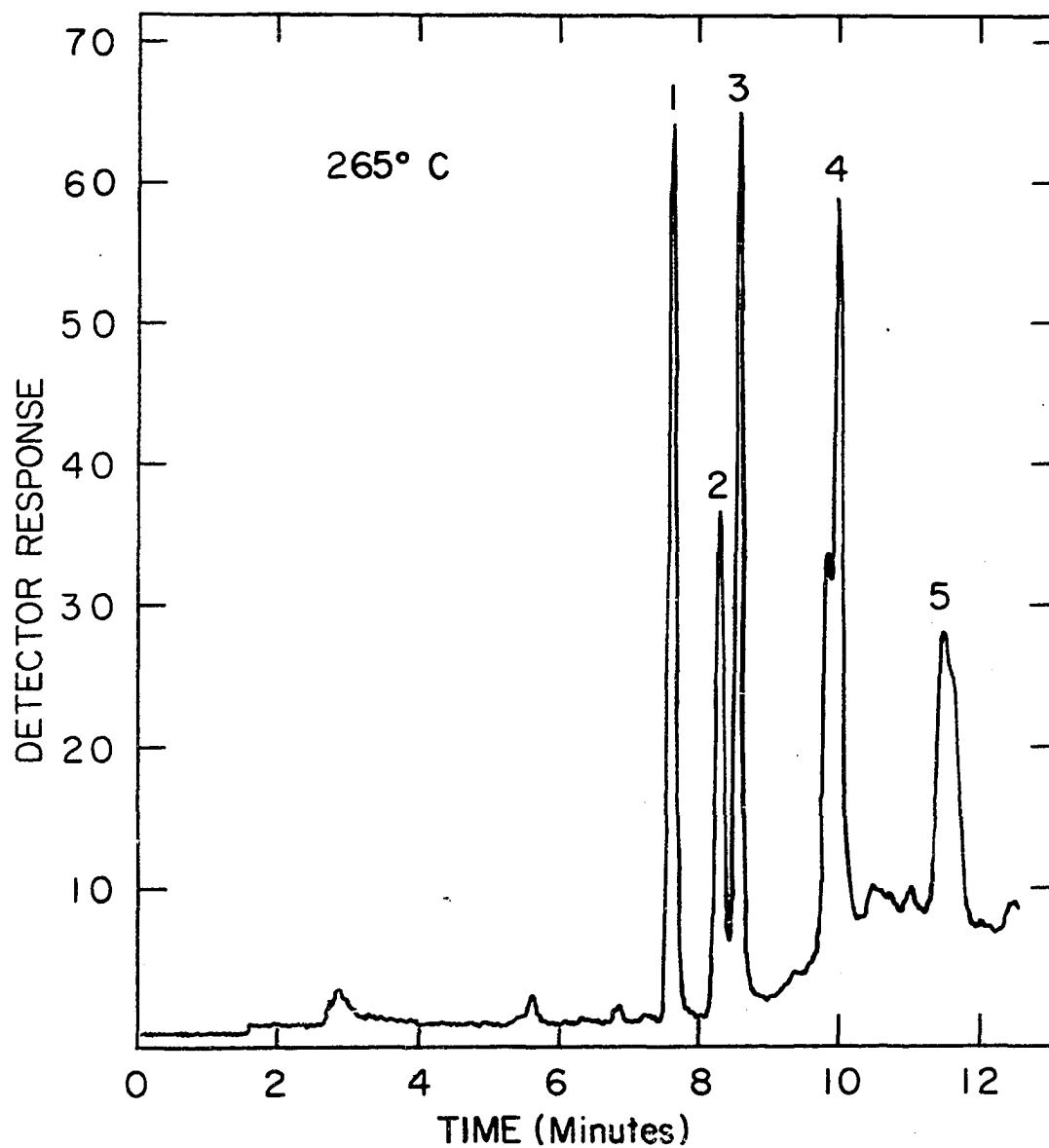

Figure 14. Gas chromatogram of model compounds in spiked water. Same conditions as in Figure 12 except desorption temperature: 265 C

volatile compounds like octane, benzene and toluene, but loss for higher-boiling compounds is more serious. In our procedure (step 3) it was convenient to desorb at 220 C because this temperature was used for desorption of the XAD-2 tube in the other GC injection port. However, the results in Figure 14 indicate that a higher temperature (265 C, for example) would be advantageous.

Desorption time Figure 15 shows that benzene is desorbed much more quickly than naphthalene, which is less volatile. At a time of 10 min desorption of naphthalene is complete and there is no loss of benzene. No attempt was made to optimize the desorption times for the wide variety of compounds tested.

Sample size The ability of the XAD-2 mini-sampler tubes to retain organic compounds from water samples larger than 15 ml was checked in two ways. Injection of a standard sample of benzene and toluene (in 2 microliters of methanol), followed by washing the tube with 100 ml of distilled water showed no measurable loss of the organic solutes. The second method was to analyze three different water samples. The recoveries were similar as shown in Table 6.

The larger XAD-2 sampler used earlier (42) contained 2000 mg of resin and effectively removed organic impurities from at least 50 liters of water. The mini-sampler contains 80 mg of XAD-2 and would be expected to be effective with water samples as large as one liter. In one instance a one liter sample was



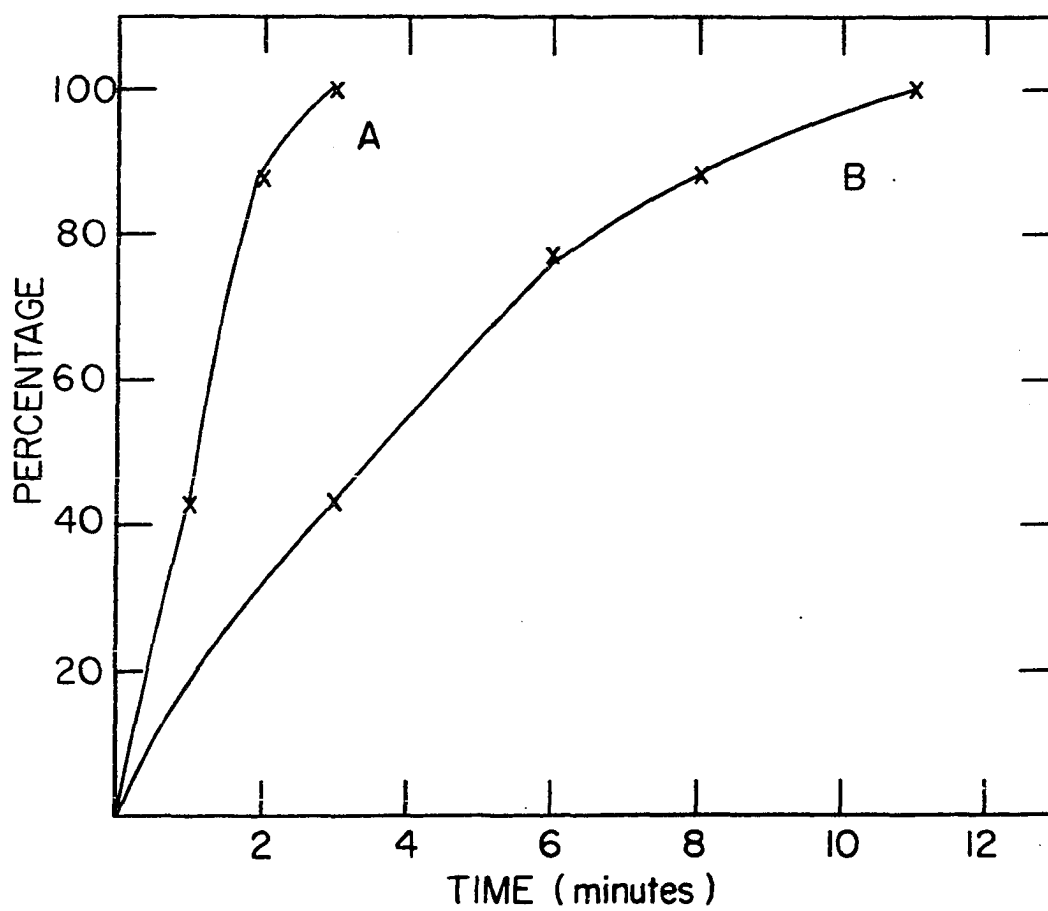

Figure 15. Effect of the desorption time. (A) benzene, (B) naphthalene

Table 6. Effect of water sample size (in recovery percentage)

Compound	15 ml	60 ml	100 ml
Acetone	49	60	56
Benzene	90	90	92
Toluene	97	102	101

successfully analyzed for chloroform and other halocarbons.

Linearity Figure 16 shows that a linear dependence of peak height on concentrations of trace organic can be established.

Sensitivity Based on a 15-ml water sample, the method is capable of detecting 0.1 ppb of organic compound in water assuming a detector sensitivity (FID) of 1 ng. The sensitivity can be improved by using a larger sample size.

#### Analysis of real water for organics

Drinking water supplies of two small communities near Ames were analyzed for trace organics using the described method. Two gas chromatograms of these analyses are shown in Figures 17 and 18. No quantitative and qualitative data were obtained. These chromatograms only represent a general profile of the organic contaminants in the drinking water to demonstrate the described method's capability of analyzing real water samples for trace organics. Each sample was run in duplicate to check its reproducibility.

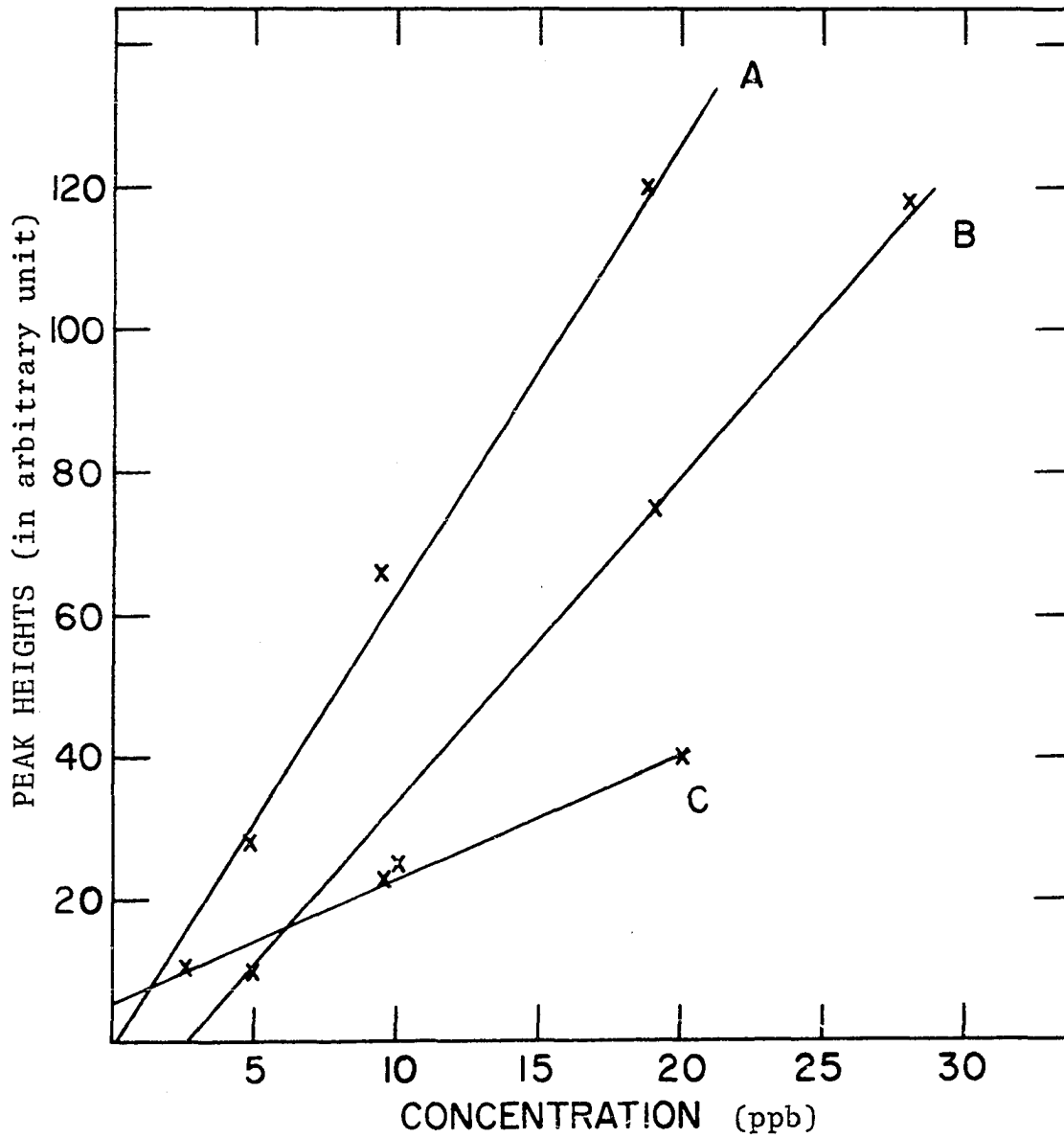

Figure 16. Linear relationship between peak heights and the concentration organic compounds in spiked water in ppb region: (A) toluene, (B) benzene, (C) acetone

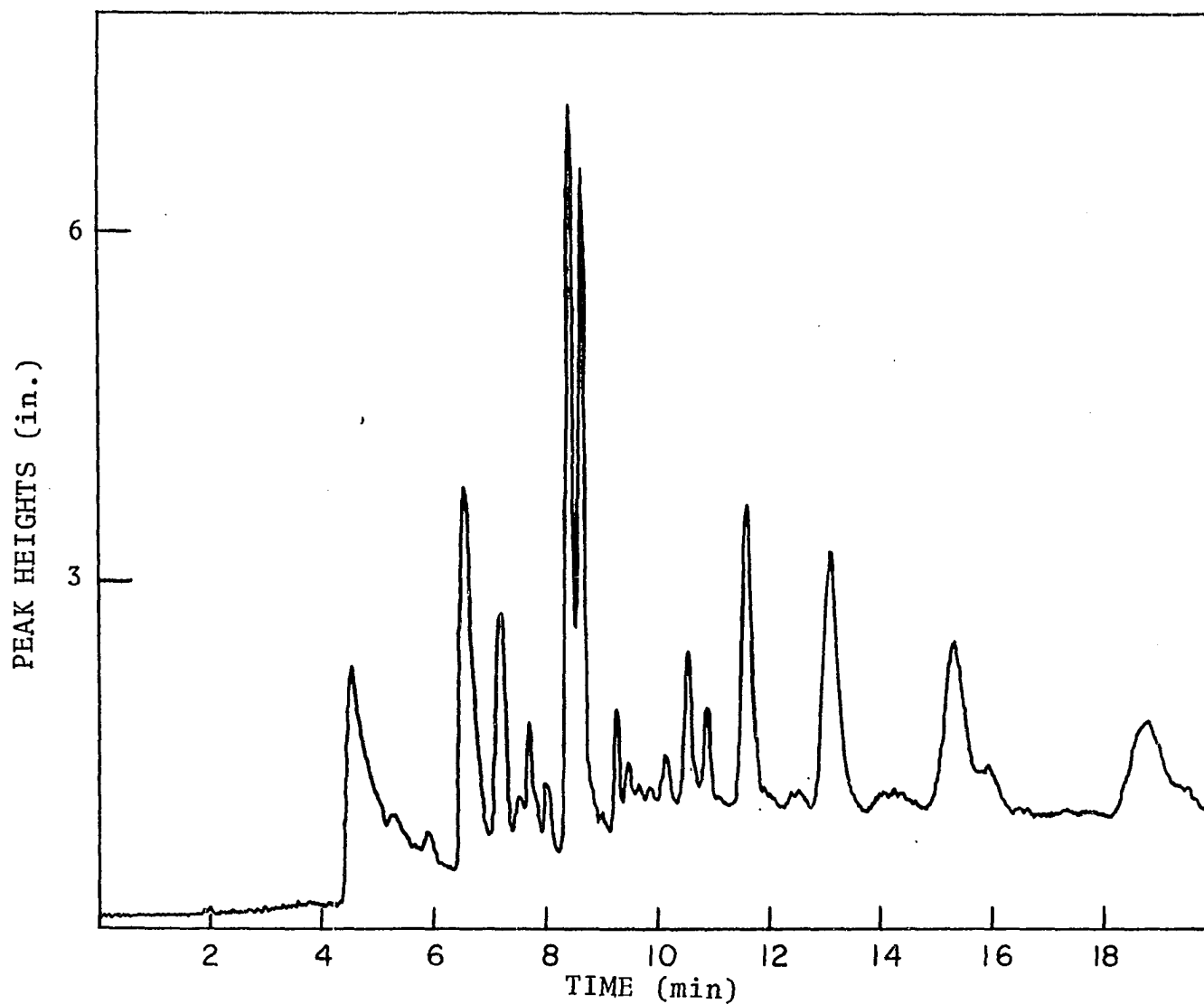

Figure 17. Gas chromatogram of organic compounds extracted from drinking water of Slater, Iowa

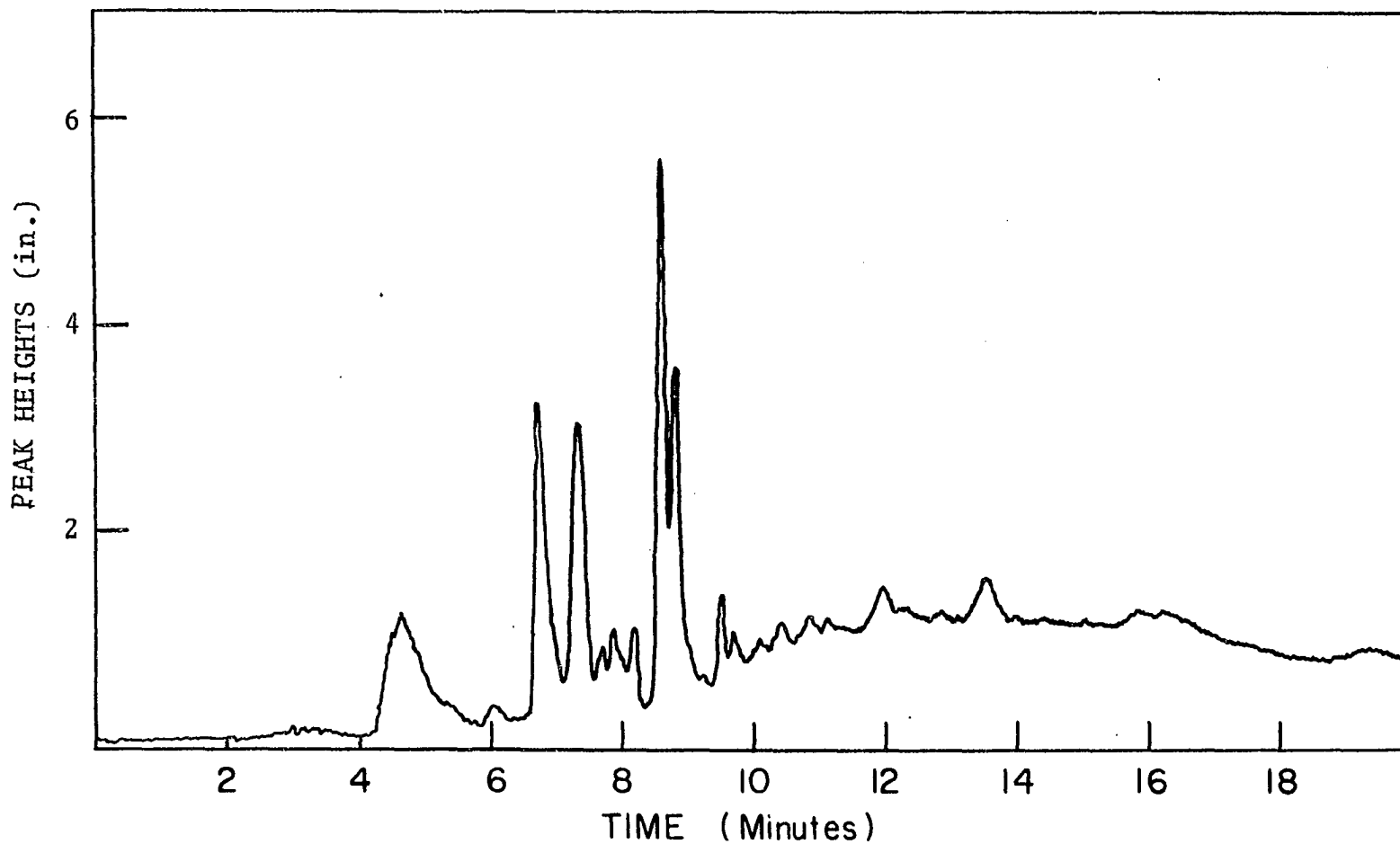

Figure 18. Gas chromatogram of organic compounds extracted from the drinking water of Clive, Iowa

### Conclusion

The described method is capable both to volatile compounds such as chloroform and to less volatile compounds like naphthalene at very low concentrations. Lower molecular weight alcohols, carboxylic acids and phenols are only partially retained by the resin and give low recovery results. This method may not be applicable to compounds that boil much higher than naphthalene. Despite these limitations, this appears to be the most promising general procedure yet reported for concentrating and determining trace levels of organic compounds from small samples of water. Furthermore, since all the organic impurities removed from water are used for gas chromatographic analysis, a much smaller water sample can be used than formerly possible. This means that field sampling with immediate sorption onto a mini-sampler is now feasible. It should be an excellent method for routine monitoring of pollutants known to be in drinking water.

## CONCENTRATION AND DETERMINATION OF HALOMETHANES

In 1974, chloroform and related compounds were found in some drinking water supplies (85,86). An EPA survey of 79 cities conducted in 1975 (87) found these chlorinated compounds in every city surveyed. Furthermore the concentrations reported ranged as high as 300 ppb, which is more than 100 times the concentration of other gas chromatographable organic impurities usually found in drinking water. Rook (88,89) reported that these compounds are only present in chlorinated water and are produced by chlorination of humic material which is present naturally in water. These halomethanes have been considered to be potential carcinogens; however, the author does not believe there is any immediate threat to public health. But improved analytical methods will be needed to better understand the mechanism by which these halomethanes are produced in water.

## Review of Related Work

Since the subject is very recent, there is very little available in the literature. Chloroform and related compounds in water are determined by Bellar and Lichtenberg (64) using a gas stripping gas chromatographic procedure in which the halomethanes are volatilized by purging the water with an inert gas and sorbed from the gas phase onto a polymeric sorbent such as Tenax-GC. The sorbed halomethanes are then thermally desorbed and separated by gas chromatography. The EPA used the Bellar

method in its survey but the method requires approximately 50 minutes for gas chromatographic separation plus additional time for stripping and thermal desorption. Furthermore, a special conductivity detector is needed for the procedure.

When there is adequate sensitivity available for the compounds of interest there is no need to complicate the procedure with a thermal device. For example, 10 picograms of halomethanes can be detected by electron capture detector (EC) while hydrocarbons have little response for EC.

In this work, a simple and rapid procedure was developed based on that previously described in the last section in which water sample is passed rapidly through a mini-column containing XAD-2. The sorbed halomethanes are eluted with 2.0 ml of methanol. An aliquot of methanol is injected immediately into a Tenax-GC gas chromatographic column where they are separated and determined by electron capture gas chromatography. In this work, any standard electron capture detector can be used and a complete separation of halomethanes is achieved in less than 20 minutes.

## Experimental

### Apparatus and reagents

Gas chromatograph A Tracor Model 550 gas chromatograph equipped with  $^{63}\text{Ni}$  electron capture and linearizer was used to determine halomethanes. All chromatograms were recorded on a Fisher Recordall Series 5000 recorder.



Extraction apparatus A schematic diagram of the extraction apparatus is shown in Figure 19 in which water samples were forced through the mini-column (H) with the aid of gas pressure (A). A Teflon needle valve (C) was used to ensure the pressure inside 1-liter glass reservoir (D).

Water Water freed of volatile organics was prepared by purging the laboratory distilled water with helium.

Resin Amberlite XAD-2 was obtained from Rohm and Haas, 5000 Richmond Street, Philadelphia, Pennsylvania. The resin as received from the supplier was ground to small particles and sieved dry. Only 60-80 mesh portion was purified by sequential solvent extractions with methanol, acetonitrile ethyl ether in a Soxhlet extractor for eight hours per solvent. The resin was then stored in a glass-stoppered bottle to maintain its purity.

#### Techniques and procedure

Sorption columns preparation Pyrex tubings, 10 cm by 2 mm i.d., were modified to accept Altex connector. Each column was filled with XAD-2, 60-80 mesh (approximately 80 mg). Each column was conditioned by sequential elution with ethyl ether, methanol, acetone and methanol. This was done by passing 10 ml of each eluting solvent through the mini-column with a syringe.

Packing and conditioning of Tenax-GC column A 6 ft by 0.25 in. o.d. glass column was packed with Tenax-GC, 60-80

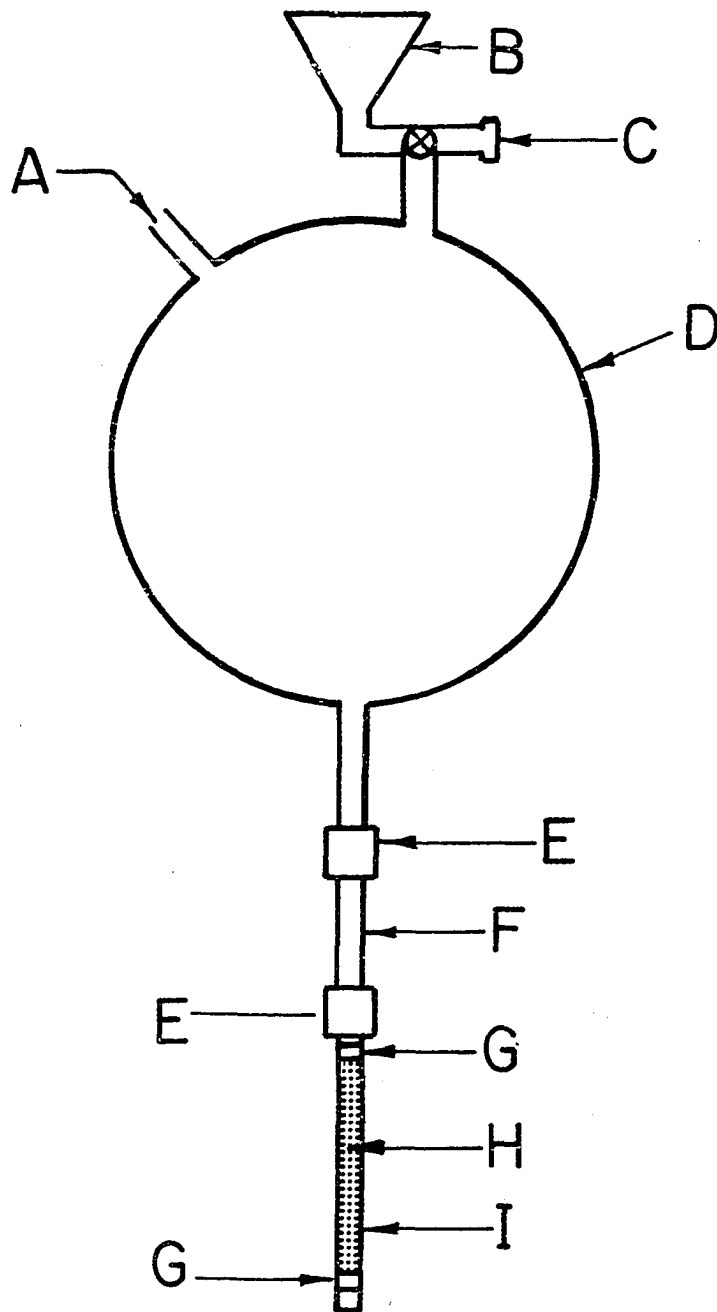

Figure 19. Extraction apparatus for extracting halomethanes: (A) pure inert gas pressure source; (B) funnel; (C) Teflon valve; (D) one-liter reservoir; (E) Altex connector; (F) Kel-F fitting; (G) solanized glass wool plugs; (H) XAD-2; (I) mini-column

mesh, under mild vacuum. The following conditioning procedure was found to be satisfactory: helium was passed through the column at a rate of 15 ml/min for an hour at room temperature. Without interrupting the gas flow, the column was heated at a rate of 10 C/min from room temperature to 240 C and held the column temperature at this temperature for 24 hours and then the column temperature was allowed to cool to 200 C. The argon/methane mixture was then passed through at a rate of approximately 40 ml/min for another 24 hours. The mixture of halomethanes was injected several times before a quantitative result was made because the Tenax-GC packing must adjust itself to the mixture to be separated.

Analytical procedure for determination of halomethanes

Halomethanes in spiked and real water samples were determined according to the following procedure:

1. Water sample was passed through the mini-column containing XAD-2 using a helium head pressure at a flow rate of 15 ml/min. After all the water sample had passed through, the head pressure helium was allowed to pass through the mini-column.

2. Halomethanes were then eluted with 2 ml of methanol into a 2-ml volumetric flask.

3. An aliquot (2  $\mu$ l) of methanol was injected into a gas chromatograph for separation using the following parameters:

Packing: Tenax-GC, 60-80 mesh

Detector:  $^{63}\text{Ni}$  electron capture

Column dimension: 6 ft by 0.25 in. o.d. glass

Carrier gas: Argon/methane, 90/10.

Temperature:

Detector: 240 C

Column: Initial 100 C, followed by 5 C/min increase to 180 C and final hold of four minutes.

4. Halomethanes were identified by comparing their retention times with those of the standards. Their concentrations were determined by comparing their peak heights with those of the standards.

## Results and Discussion

### Recovery studies

Known amounts of four halomethanes were added to the volatile organic-free water and analyses were performed by the described procedure above. The results are summarized in Table 7.

Table 7. XAD-2 extraction efficiency (in percent) of halomethanes from 100 ml spiked water samples

Compounds	0.5 ppb	1.0 ppb	10 ppb
Chloroform	55	56	58
Bromodichloromethanes	60	68	70
Dibromochloromethane	82	80	85
Bromoform	98	100	102

Water samples containing four halomethanes were analyzed three times with average recovery percentages as given in the table. Although the recovery ranged from 55% to 100% depending on the individual compound, they were consistent over the range tried. A typical chromatogram of a spiked water sample containing five halomethanes is shown in Figure 20. A complete separation of these halomethanes was achieved in less than 20 minutes using temperature programmed gas chromatography. Temperature program with electron capture is a bit unusual because it used to be considered as something that was best avoided in electron capture gas chromatography (EC-GC). Since baseline shifts a great deal with the conventional column packing, it was considered impossible to apply the temperature program in EC-GC. In this study, a relatively steady baseline is obtained using temperature program. The main reason for this success is the extremely low column bleed from Tenax-GC.

#### Analysis of water for halomethanes

Halomethanes in Iowa State University tap water were determined by the described method without modification. Variation of halomethane concentrations in tap water is shown in Table 8.

The concentrations of the individual compounds were calculated using the following recovery percentages: chloroform 60%, bromodichloromethane 70%, dibromochloromethane 80% and

Figure 20. A chromatogram of a spiked water sample: (A) chloroform; (B) carbon tetrachloride; (C) bromodichloromethane; (D) dibromochloromethane; (E) bromoform

Spiked Sample

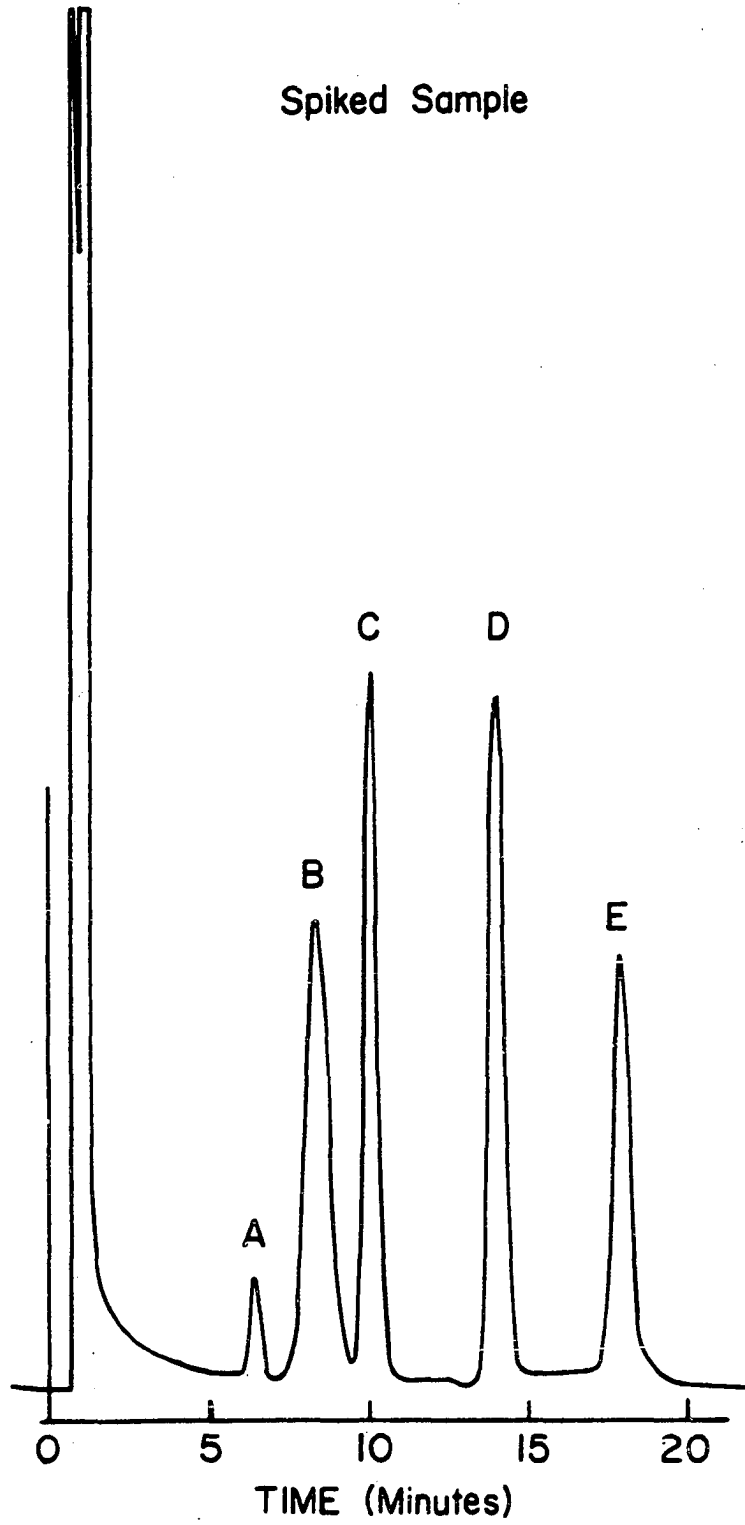

Table 8. Variation of halomethane concentrations in Iowa State University tap water (in ppb)<sup>a</sup>

Sampling date	CHCl <sub>3</sub>	CHCl <sub>2</sub> Br	CHClBr <sub>2</sub>	CHBr <sub>3</sub>
3-22-76	12	5	9.1	1.3
3-23-76	14	4.8	8.5	1.0
3-24-76	15	3.8	7.0	0.8
4-1-76	12	5.8	8.5	1.0

<sup>a</sup>200 ml of tap water was used for analysis. Concentrations were calculated based on following percentage recoveries: CHCl<sub>3</sub> 60%, CHCl<sub>2</sub>Br 70%, CHClBr<sub>2</sub> 80% and CHBr<sub>3</sub> 100%.

and bromoform 100%. Samples were run in duplicate each time.

Distilled water samples were also analyzed using the described method. Only detectable amounts of halomethanes were found in those samples.

A chromatogram illustrating the halomethane content from 100 ml of drinking water from Slater, Iowa is shown in Figure 21. The chromatographic features and stability for this real water sample are comparable to those shown for the spiked sample. The unknown peak found in this water sample was not present in Iowa State University tap water or distilled water. The concentration of this component was estimated to 10 ppb.

#### Method parameters

Elution of halomethanes Junk et al. (42) recently measured the comparative elution efficiencies of ethyl ether and methanol for a wide variety of organic compounds sorbed on XAD-2 resin. They found that methanol is about as effec-



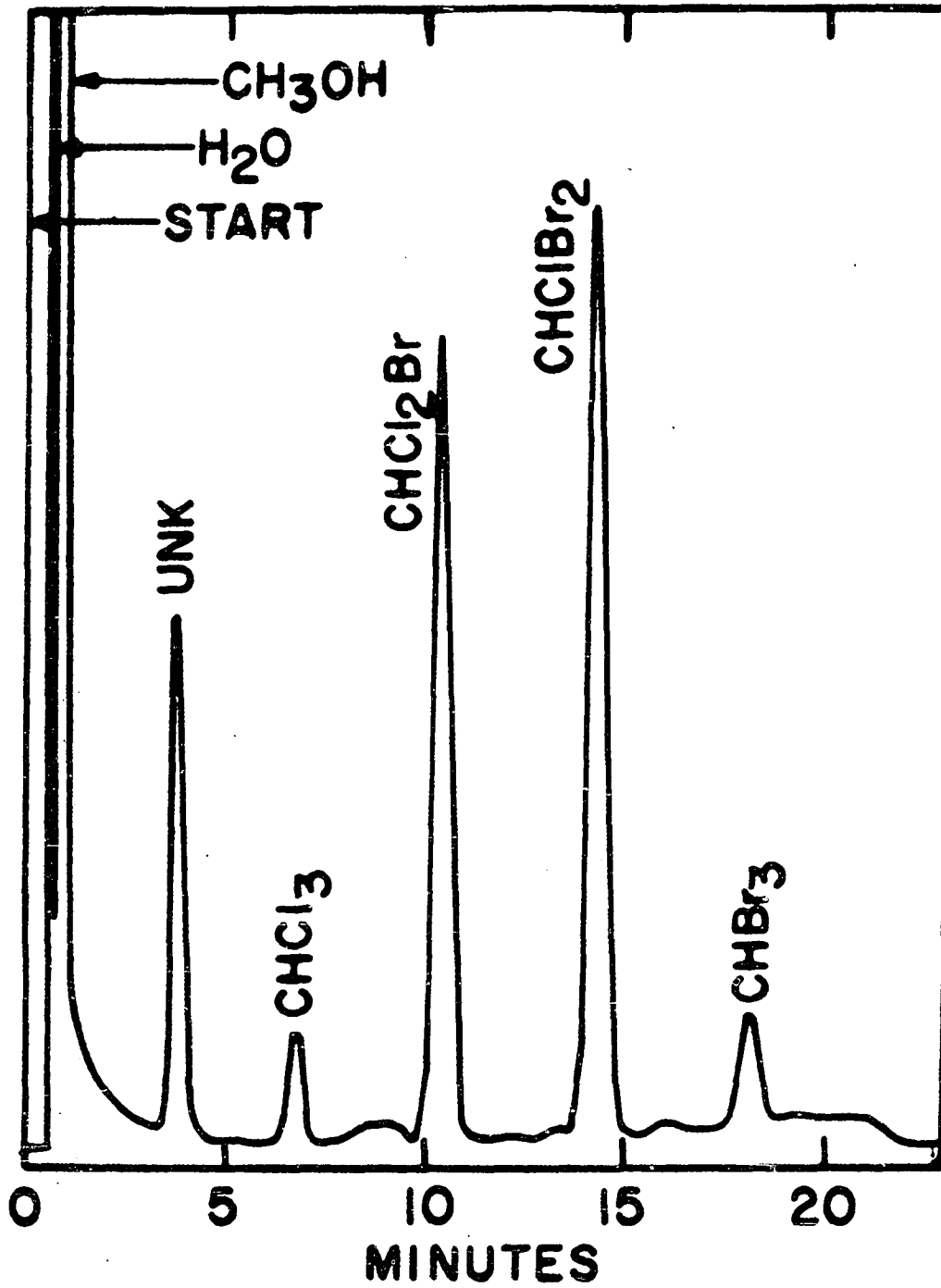

Figure 21. A chromatogram of halomethanes extracted from drinking water of Slater, Iowa

tive as ethyl ether in stripping the sorbed organic halides from the resin. Methanol is also totally miscible with water, therefore no drying step is necessary. In this work, it was found that 2 ml of methanol is sufficient for complete elution of halomethanes sorbed on the mini-column containing XAD-2. Methanol is therefore recommended as the eluting agent in this procedure.

Gas chromatographic column Tenax-GC column was chosen for its extremely low bleed, short retention times for both water and methanol; for example, both water and methanol elute from the 6 ft column in less than 2 minutes at 100 C column temperature. Tenax-GC also has relatively longer retention times for halomethanes. These combinations result in an ideal GC column for separation of halomethanes as shown in Figures 20 and 21.

Sensitivity Based on a 100 ml water sample and a detector sensitivity (EC) of 10 picograms, the method is capable of detecting 0.1 ppb of halomethanes. Sensitivity can be increased, if necessary, by using a larger water sample.

#### Storage of sorbed halomethanes

In order to test the applicability of the mini-column for field sampling, water samples spiked with five volatile halomethanes (chloroform, carbon tetrachloride, bromodichloromethane, dibromochloromethane and bromoform) were chosen for testing. After the spiked water samples were forced through

the mini-column, they were stored in screw-capped test-tubes for a specific period of time before analysis. No measurable loss of the spiked halomethanes was observed after four days of storage. Although this single experiment is not conclusive, it does appear that sorbed organic compounds are stable on the mini-column of XAD-2 for several days.

#### Conclusion

The described method for halomethanes is rapid and simple. The total time for an analysis is about 45 minutes. It may be extended to determine other less volatile halocarbons.

## SUGGESTIONS FOR FUTURE WORK

The resin extraction-thermal desorption method described in this thesis is crude, developed to prove the value of this approach in analyzing water for trace organics. The method needs some refinements before it can be used routinely in other laboratories. A separate thermal unit for multiple mini-columns for the first thermal desorption step will be helpful so that the temperature of the second thermal desorption step can be adjusted to a much higher temperature for better elution of sorbed organics from the Tenax-GC column.

Capillary column was suggested at the inception of this project but was not incorporated. Its use in water analysis has been proved and it is most frequently used. It offers better resolution and sensitivity.

Specific detectors, for example, nitrogen-specific, flame photometric, etc. are available. These detectors offer a significant increase in both sensitivity and selectivity as compared to flame ionization detector (FID) for specific compounds of interest. Methods can be designed for specific classes of compounds. Some of these advantages were demonstrated in the method for halomethanes in water described in this thesis.

Storage of sorbed organics on the mini-column should be further studied.

The mini-column approach can be further scaled down so

that 100-200  $\mu$ l of an eluting agent will be sufficient to quantitatively elute the sorbed organics.

Finally, to automate the resin extraction-thermal desorption method will be very desirable for routine monitoring of trace organics in water and wastewater.

## LITERATURE CITED

1. C. C. Johnson, Transcript: Safe Drinking Water, Series No. 92-24, U.S. Government Printing Office, Washington, D.C., 1971, p. 58.
2. J. H. Lehr, Transcript: Safe Drinking Water, Series No. 92-24, U.S. Government Printing Office, Washington, D.C., 1971, p. 125.
3. M. W. Ellis, U.S. Dept. Commerce, Bureau of Fisheries Bulletin 22 (1937).
4. W. D. Beer, Wiss. Z. Karl Marx Univ., 8, 67 (1959).
5. "Standard Methods for the Examination of Water and Waste Water," 13th ed., American Public Health Association, New York, N.Y., 1971, p. 281.
6. "Standard Methods for the Examination of Water, Sewage and Industrial Wastes," 10th ed., American Public Health Association, New York, N.Y., 1955, p. 164.
7. E. Eisenstaedt (Emerson), J. Org. Chem., 3, 153 (1938).
8. E. Emerson, J. Org. Chem., 8, 417 (1943).
9. E. Emerson and K. Kelly, J. Org. Chem., 13, 532 (1948).
10. American Society for Testing and Materials, Method D-1783-70, Philadelphia, Pa., 1970.
11. "Standard Methods for the Examination of Water and Waste Water," 13th ed., American Public Health Association, New York, N.Y., 1971, p. 501.
12. H. D. Gibbs, J. Biol. Chem., 71, 445 (1927).
13. H. V. Burba, Anal. Biochem., 24, 334 (1968).
14. E. Sunbt, J. Chromatogr., 6, 475 (1961).
15. E. Stahl, "Thin Layer Chromatography," Academic Press, New York, N.Y., 1965.
16. G. J. Kapadia, J. R. Mosby, G. G. Kapadia and T. B. Zalucky, J. Pharm. Sci., 54, 41 (1965).
17. L. Lykkon, R. Treseder and V. Zahn, Ind. Eng. Chem., Anal. Ed., 18, 103 (1946).

18. H. O. Friestad, P. E. Ott and F. A. Gunther, *Anal. Chem.*, 41, 1750 (1969).
19. A. S. Wexler, *Anal. Chem.*, 35, 1936 (1963).
20. L. J. Schmauch and H. M. Grubb, *Anal. Chem.*, 26, 309 (1954).
21. E. F. Mochler, Jr. and L. N. Jacob, *Anal. Chem.* 29, 1369 (1963).
22. J. E. Fountaine, P. B. Joshipura, P.N. Keliher and J. D. Johnson, *Anal. Chem.*, 46, 62 (1974).
23. P. A. St. John, *Water Pollution Handbook*, 4, 1663 (1973).
24. R. G. Simard, I. Hasegawa, W. Bandaruk and C. E. Headington, *Anal. Chem.*, 23, 1384 (1951).
25. E. Aider, K. Holmberg and L. Ryfors, *Acta Chem. Scand.*, Ser. B. 28, 8 (1974).
26. L. Atuma, *Analyst*, 98, 886 (1973).
27. J. Sherma and L. V. S. Hood, *J. Chromatogr.*, 17, 307 (1965).
28. D. Locke and J. Sherma, *Anal. Chim. Acta*, 25, 312 (1961).
29. I. T. Clark, *J. Chromatogr.*, 15, 65 (1964).
30. L. Reid, *J. Chromatogr.*, 88, 119 (1974).
31. D. L. Gumprecht, *J. Chromatogr.*, 18, 336 (1965).
32. P. Jandera and J. Churacek, *J. Chromatogr.*, 86, 423 (1973).
33. J. Rexfelt and O. Samuelson, *Anal. Chim. Acta*, 70, 375 (1974).
34. A. W. Wolkoff and R. H. Larose, *J. Chromatogr.*, 99, 731 (1974).
35. R. A. Baker and B. A. Malo, *Environ. Sci. Technol.*, 1, 997 (1967).
36. R. A. Baker, *J. Amer. Water Works Assoc.*, 58, 751 (1966).
37. R. A. Baker, *J. Air and Water Pollution*, 10, 591 (1966).

38. American Society for Testing Materials, Method D-2580-68, Philadelphia, Pa., 1970.
39. "Standard Methods for the Examination of Water and Waste Water," 13th Ed., American Public Health Association, New York, N.Y., 1971, p. 510.
40. A. W. Briedenback, J. J. Lichtenberg, C. F. Henke, D. J. Smith, J. W. Eichelberger and H. Steirli, U.S. Dept. of Interior Publication WP-22 (1966).
41. J. S. Eichelberger, R. C. Dressman and J. E. Longbottom, Environ, Sci. Technol., 4, 576 (1970).
42. G. A. Junk, J. J. Richard, M. D. Grieser, D. Witiak, J. L. Witiak, M. D. Arguello, R. Vick, H. J. Svec, J. S. Fritz and G. V. Calder, J. Chromatogr., 99, 745 (1974).
43. J. A. Vinson, G. A. Burke, B. L. Flager, D. R. Carper and W. A. Nylander and R. J. Middlemiss, Environ. Letters, 5, 199 (1973).
44. J. S. Fritz and T. A. Tateda, Anal. Chem., 40, 2115 (1968).
45. R. B. Dean, News Environ. Res., Environmental Protection Agency, Cincinnati, Ohio, July 5, 1974.
46. W. W. Meinke and J. K. Taylor, "Analytical Chemistry: Key to Progress on National Problem," National Bureau of Standards Special Publication 351, U.S. Government Printing Office, Washington, D.C., 1972.
47. P. R. Musty and G. Nickless, J. Chromatogr., 89, 185 (1973).
48. M. Ahnoff and B. Josefsson, Anal. Chem., 46, 658 (1974).
49. R. A. Hites, J. Chromatog. Sci., 11, 570 (1973).
50. M. C. Goldberg, L. Delong and M. Sinclair 45, 89 (1973).
51. B. M. Austern, R. A. Dobbs and J. M. Cohen, Environ. Sci. Technol., 6, 588 (1975).
52. C. McAuliffe, Chem. Tech. 1, 46 (1971).
53. K. Grob, K. Grob, Jr. and G. Grob, J. Chromatogr., 106, 299 (1975).



54. A. Zlatkis, W. Bertsch, H. A. Lichtenstein, A. Tishbee, F. Shunbo, H. M. Leibich, A. M. Coscia and N. Fleischer Anal. Chem., 45, 763 (1973).
55. A. Zlatkis, H. A. Lichtenstein and A. Tishbee, Chromatographia 6, 67 (1973).
56. A. Zlatkis, W. Bertsch, D. A. Dafus and H. M. Liebich, J. Chromatogr., 91, 379 (1974).
57. W. Bertsch, R. C. Chang and A. Zlatkis, J. Chromatog. Sci., 12, 175 (1974).
58. W. Bertsch, A. Zlatkis, H. M. Liebich and H. F. Schneider, J. Chromatogr., 99, 673 (1974).
59. W. Bertsch, E. Anderson and G. Holzer, J. Chromatogr., 112, 701 (1975).
60. J. W. Swinnerton and V. J. Linnenbom, J. Gas Chromatogr., 5, 570 (1967).
61. J. W. Swinnerton and R. A. Lamontagne, Environ. Sci. Technol., 8, 657 (1974).
62. K. Grob, J. Chromatogr., 84, 225 (1973).
63. K. Grob and G. Grob, J. Chromatogr., 90, 303 (1974).
64. T. A. Bellar and J. J. Lichtenberg, J. Amer. Water Works Assoc., 66, 739 (1974).
65. C. M. Weiss, J. D. Johnson and B. Kwan, J. Amer. Water Works Assoc., 55, 1367 (1963).
66. R. A. Baker, J. Amer. Water Works Assoc., 58, 751 (1966).
67. S. P. Faust and O. M. Aly, J. Amer. Water Works Assoc., 54, 235 (1962).
68. J. W. Sugar and R. A. Conway, J. WPCF, 40, 1622 (1968).
69. American Society for Testing Materials, Method D-2908-70T, Philadelphia, Pa., 1970.
70. R. A. Baker, J. Amer. Water Works Assoc., 56, 92 (1964).
71. A. W. Breidenbach, U.S. Public Health Service Publication, 1241 (1964).

72. R. W. Buelow, J. K. Carswell and J. M. Symmons, J. Amer. Water Works Assoc. 65, 57 (1973).
73. A. K. Burnham, G. V. Calder, J. S. Fritz, G. A. Junk, H. J. Svec and R. Willis, Anal. Chem., 44, 139 (1972).
74. A. K. Burnham, G. V. Calder, J. S. Fritz, G. A. Junk, H. J. Svec and R. Vick, J. Amer. Water Works Assoc., 65, 722 (1973).
75. R. L. Gustafson, R. L. Albright, J. Heisler, J. A. Lirio and O. T. Reid, Ind. Eng. Chem. Prod. Res. Develop., 1, 107 (1968).
76. J. P. Mieure and M. W. Dietrich, J. Chromatog. Sci., 11, 559 (1973).
77. W. V. Ligon, Jr. and R. L. Johnson, Jr., Anal. Chem., 48, 481 (1976).
78. H. Hackenberg, "Industrial Gas Chromatographic Trace Analysis," Heyden and Son Ltd., New York, N.Y., 1973, p. 133.
79. K. Fischer, Angew. Chem., 48, 394 (1935).
80. B. Smith, Acta Chem. Scanda., 13, 480 (1959).
81. O. L. Hollis and W. V. Hayes, J. Gas Chromatogr., 4, 236 (1966).
82. G. M. Neuman, Z. Anal. Chem., 244, 302 (1969).
83. T. A. Gough and C. F. Simpson, J. Chromatogr., 51, 129 (1970).
84. Tenax GC Bulletin, No. 24, Applied Sci., Lab., Inc., State College, Pa.
85. B. Dowty, D. Carlisle, J. L. Laseter, Science, 187, 75 (1974).
86. T. A. Bellar, J. J. Lichtenberg and R. C. Kroner, J. Amer. Water Works Assoc., 66, 703 (1974).
87. "Region V Joint Federal/State Survey of Organics and Inorganics in Selected Drinking Water Supplies," U.S. Environmental Protection Agency, Chicago, Illinois, 1975.

88. J. J. Rook, J. Water Treatment Examination, 23, 234 (1974).
89. J. J. Rook, J. Amer. Water Works Assoc., 68, 168 (1976).

## ACKNOWLEDGEMENTS

The author is grateful for the guidance of Professor James S. Fritz throughout the course of this study.

Part of the determination of phenols was a joint project with Colin D. Chriswell and was published in Analytical Chemistry.

The help of Dean D. Woods with machining of special fittings is gratefully acknowledged.

The efficient typing and format advice of Verna J. Thompson is sincerely appreciated.

I am also grateful to the members of Analytical Chemistry Groups I and II, with whom I spent many pleasurable and informative hours.

The love and understanding of my wife, Serlina, has been a continuous inspiration to me.

Special thanks are extended to my eighteen-month-old son, Christopher, for his generous offer to help in anyway he can.